

Instruction manual
DKS DUNGS Kitchen Safeguard
MPA 41xx ECS
System for monitoring the safe exhaust gas evacuation accord. to DVGW worksheet G631 (A).

1. Target group

The target group of this manual are **qualified personnel of the gas safety and regulating technology, skilled personnel or the persons instructed by them.**

Due to their specialist training, knowledge and experience and knowledge of standard regulations, they are capable of evaluating the work assigned to them and recognising possible dangers. Only they are permitted to carry out assembly, commissioning, settings and maintenance on the devices in compliance with the recognised rules for occupational safety.



DUNGS[®]
Kitchen Safeguard

Hang this instruction manual in a readily visible place inside the installation room! Do not carry out any work until you have read the safety instructions of this instruction manual.

2. Warnings

2.1 General warnings



The recognised occupational safety rules and accident prevention regulations must be observed and, if necessary, personal protective measures must be taken.



All adjustments and settings should only be performed in accordance with the instruction manuals of the connected machines.



Never carry out work as long as gas pressure or voltage is applied. Avoid open fire. Please observe public regulations.

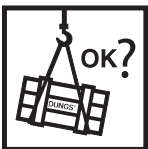

Prior to assembly, the device must be inspected for transport damage.



The device must not be exposed to open fire. Protection against lightning strikes must be guaranteed.



Connected line systems must be free from dirt and contamination.



Protection from environmental impacts and weather conditions (corrosion, rain, snow, icing, humidity (e.g. by condensation), mould, UV radiation, harmful insects, poisonous, corrosive solutions/liquids (e.g. cutting and cooling fluids)), must be guaranteed. Depending on the installation site, it may be necessary to take protective measures.



The device may only be operated in compliance with the operating conditions stated on the type plate.

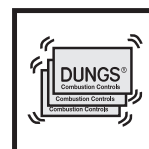

The device must be protected from vibrations and mechanical impact.



The device must not be used in areas with increased seismic risk.

Explanation of the symbols

1, 2, 3,...	=	Order of action
•	=	Instruction

2.2 Designated use

The device is used in accordance with its designated use if the following instructions are observed:

- Use of the device in gas transport and gas distribution networks, commercial and industrial plants.
- Use with gases of the 1st, 2nd and 3rd gas families according to EN 437 only.
- Use with dry and clean gases only, no aggressive media.
- Use only in compliance with the operating conditions stated on the type plate.
- Use in perfect condition only.
- Malfunctions and faults must be eliminated immediately.
- Use only in observance of the instructions given in this instruction manual and of national regulations.

2.3 Risks in case of misuse

- If used in accordance with their designated use, the devices are safe to operate.
- Non-observance of the regulations may result in personal injury or material damage, financial damage or environmental damage.
- Operator errors or misuse present risks to life and limb of the operators and also to the device and other material property.

3. Approval / declaration of conformity

EC type-examination certificate according to the EC Gas Appliances Directive:

MPA 41xx ECS

CE-0085 BU 0487

4. Contents

1. Target group	1
2. Warnings	1
2.1 General warnings	1
2.2 Designated use	2
2.3 Risks in case of misuse	2
3. Approval / declaration of conformity	2
4. Contents	3
5. General information	4
6. System description	5
6.1 Scope of the system	5
6.2 Test sequence	5
6.3 Program sequence	6
6.4 State description	7
7. MPA 41xx ECS indication	8
7.1 MPA 4111 ECS indication	8
7.2 MPA 41x2 ECS indication	9
7.3 Operation display	10
7.4 Info display	11
7.5 Error display	12
7.6 Error memory display	13
7.7 Error codes	14
8. Unlocking function	14
9. Technical data of MPA 41xx ECS	15
10. Electrical connection	16-17
11. Installation of MPA 41xx ECS	18-19
12. Function test, regularly maintenance and recurrent testing	20
13. System Accessories	21

5. General information

The MPA 41xx ECS (Exhaust Control System) serves for monitoring the safe exhaust gas evacuation according to the requirements of the DVGW (German Technical and Scientific Association of Gas and Water) worksheet G631 (A).

Program sequence predefined by the MPA 41xx ECS control unit ensures the permanent monitoring of the exhaust air system.

As soon as the (suction) pressure in the exhaust air system falls below a limit, safety valves connected to the MPA 41xx ECS are closed immediately.

In addition, the gas pressure can be monitored before and during operation in terms of safety, so that the gas valves are also closed as soon as the pressure falls below a limit.

MPA 41xx ECS version:

MPA 4111 ECS plastic housing without display

MPA 4112 ECS plastic housing with display

MPA 4122 ECS die-cast aluminium housing with display, paint is food safe

Application

The MPA 41xx ECS serves for monitoring the safe exhaust gas evacuation according to the requirements of DVGW (German Technical and Scientific Association of Gas and Water) worksheet G631 (A), March 2012

Approvals

EC type-examination certificate according to the EC Gas Appliances Directive:

MPA 41xx ECS CE-0085 BU 0487

6. System description DKS

6.1 Scope of the system

The system consists of:

- MPA 41xx ECS control unit (1)
- Air pressure switch for monitoring the exhaust air fan (2)*
- Double solenoid valve (or two single solenoid valves connected in series) (3)*
- Gas pressure switch for monitoring the min. gas pressure (optional) (4)*
- Thermal equipment trip (5)

* see section 13.

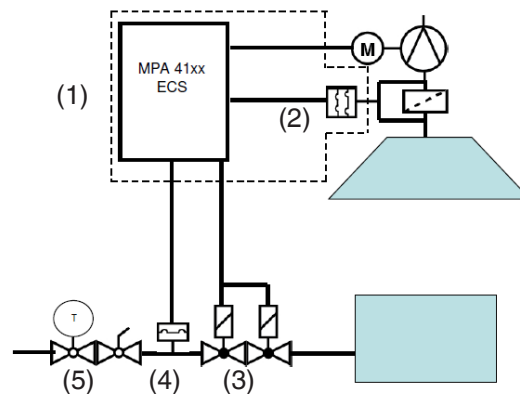

6.2 Test sequence

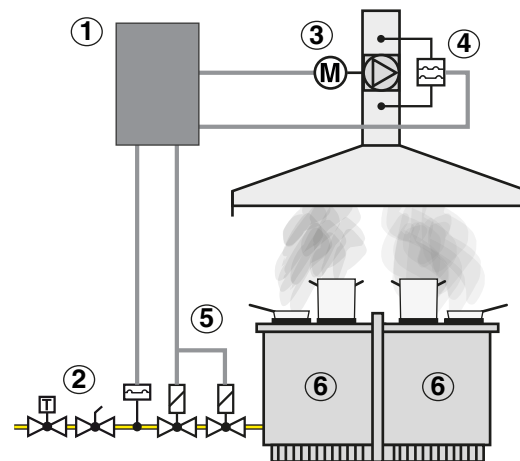

1.	After the manual test request (1), the closed position of all turn-off devices of the safety chain (e.g. open position of the fresh air flap) and the gas inlet pressure are checked (2).
2.	The exhaust air fan (3) is supplied with voltage, the required (suction or negative) pressure is checked by means of an air pressure switch (4).
3.	The gas supply for the individual consumers is released (5).
4.	The gas consumers are operated manually (6); it is not the task of the ECS to monitor them.
5.	If the gas pressure is too low, in case of low voltage or a failure of the fan, the gas valves of the central gas supply are closed. Depending on the error that has occurred, an automatic restart or a fault lock follows.
6.	If the exhaust air system is continuously operated (> 24 h), after 24 hours the system is automatically switched off and automatically restarted to check the safety devices.

6.3 Program sequence

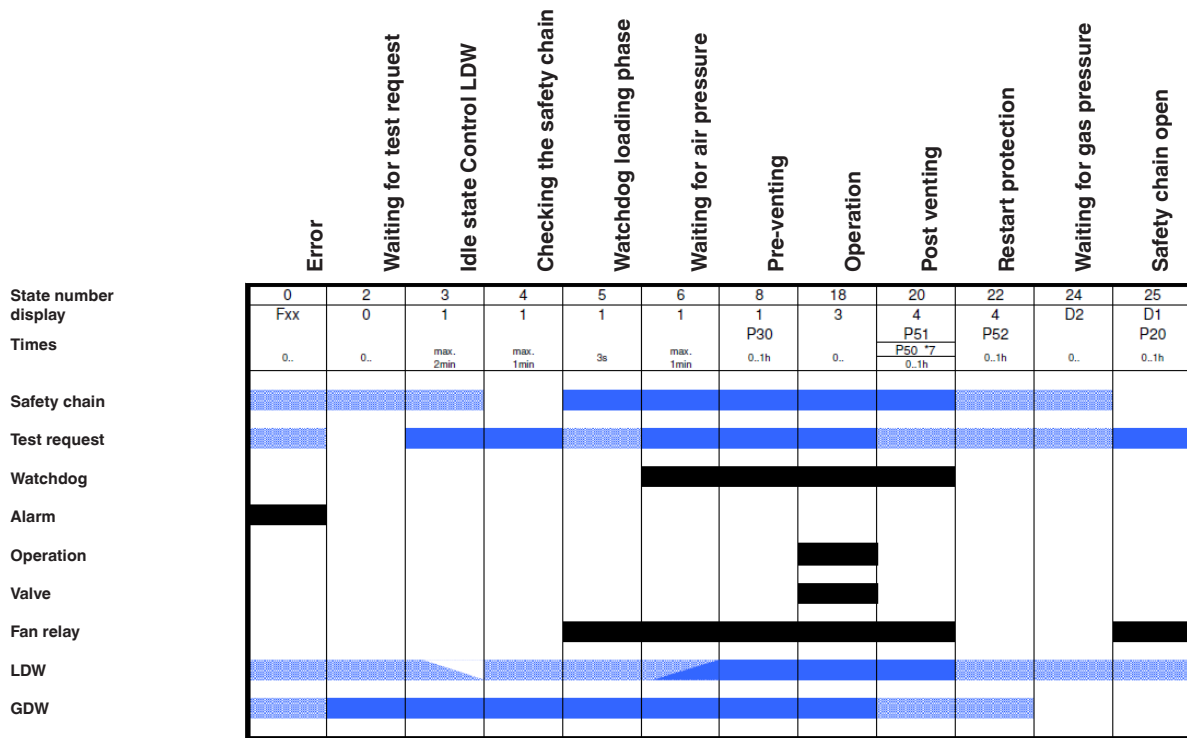

Output active
 Input active
 Any input

Safety times		
State 3	Idle state control air pressure switch	max. 120 s
State 4	Checking the safety chain	max. 60 s
State 6	Waiting for air pressure	max. 60 s
State 8	Pre-venting	10 s
State 20	Post-venting	10 s
State 22	Restart protection*	30 s
State 25	Waiting time of safety chain open	max. 60 s

***Attention:** The duration of the restart protection depends on the closing time of the flame monitoring system(s). The closing time must be checked on site and adjusted by changing the restart time if required.

6.4 State description

State 00: Error (display indication: F xx)

The indication automatically switches to the error display and displays the current error code (e.g. F 11).

State 02: Waiting for test request (display indication: 0)

The automatic control system is ready for operation, there is no test request.

State 03: Idle state control air pressure switch (display indication: 1)

Idle state control of the air pressure switch.
Maximum test time 2 minutes; if an idle state of the air pressure switch is not detected during this period of time, a restart attempt is carried out.

State 04: Checking the safety chain (display indication: 1)

Checking whether the safety chain is potential-free.
If the safety chain is not potential-free, after 60 s a restart attempt is carried out.

State 05: Watchdog loading phase (display indication: 1)

The safety-relevant watchdog switching is activated, the fan relay is on.
If the safety chain is open, state 25 is activated.

State 06: Waiting for air pressure (display indication: 1)

The required air pressure must be reached within 60 s, otherwise a restart attempt is carried out.

State 08: Pre-venting (display indication: 1)

Defined pre-venting, duration 10 seconds.

State 18: Operation (display indication: 3)

The gas valves have been opened, the system is now operating. After 23 hours and 59 minutes, the automatic control system automatically interrupts the gas supply and switches off the fan.
An automatic restart is carried out.

State 20: Post-venting (display indication: 4)

The gas valves remain closed from this state on. The fan continues running (10 s) to dissipate the remaining combustion gases.

State 22: Restart protection (display indication: 4)

Duration of the switch-on delay; a new test request is only possible after this duration has expired.

State 24: Waiting for gas pressure (display indication: d2)

The system remains in standby.

State 25: Safety chain open (display indication: d1)

The automatic control system waits for 60 s if no closed safety chain is detected.
After expiry of the waiting time, locking is carried out.

Note: Between State 08 and State 18 the display shows „2“ for a short time.

7. MPA 41xx ECS indication

The system status of the MPA 41xx ECS is represented either by LED signals (MPA 4111 ECS) or via a 3-digit 7-segment display (MPA 41x2 ECS).

7.1 MPA 4111 ECS indication

Yellow LED

Indication of the operating state

OFF: Fault

ON: Waiting for test request / test / post-venting

Flashing (0.5 Hz): Operation

Flashing (2 Hz): Waiting for gas pressure / safety chain interrupted

Red LED

Indication of the cause of the failure.

The number of flashing pulses indicates the cause of the error.

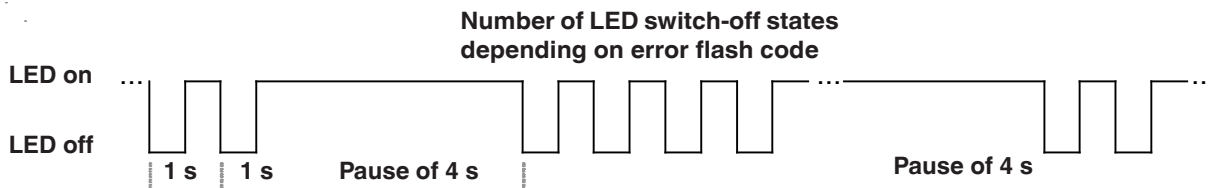
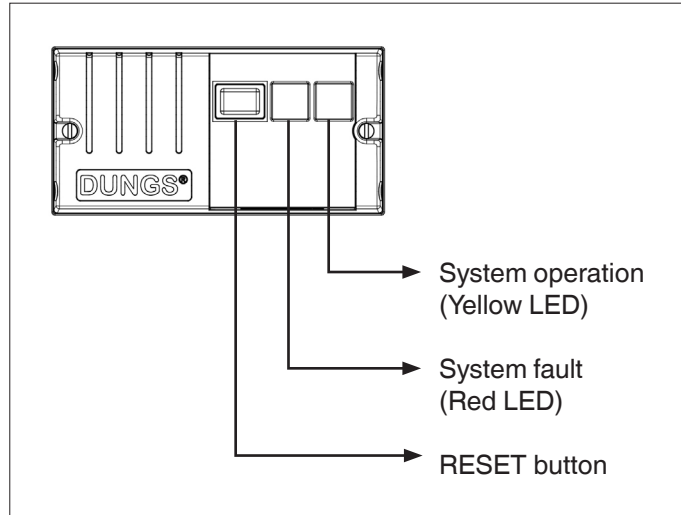

Flash code 1: Safety chain interrupted

Flash code 5: Error of idle state control
air pressure switch / no air pressure

All other flash codes: Other errors

Yellow LED and red LED



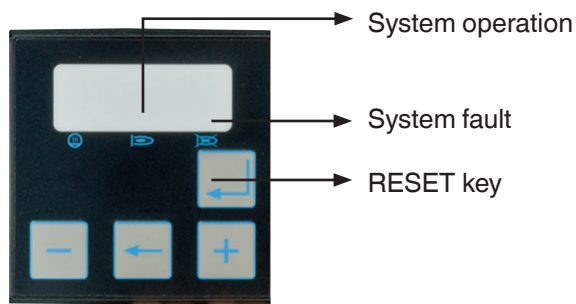

During switch-on, both LEDs are lighted twice to check functionality.

7.2 MPA 41x2 ECS indication



The 7-segment display and 3 status LEDs show the operational state/error messages of the MPA 41x2 ECS .

Overview display modes

Mode	Active
Operation display	in normal operation if no error is active.
Error display	if the automatic control system is in lockout.
Info display	From operation display by pressing a shortcut  and 
Display of the error memory	From operation display by pressing a shortcut  

Attention

Observe indication on 7-segment display

1. Digits

6 = 

8 = 

0 = 

2. Letters

B or b = 

D or d = 

O or o = 

7.3 Operation display

► Shows the operating state of the automatic control system

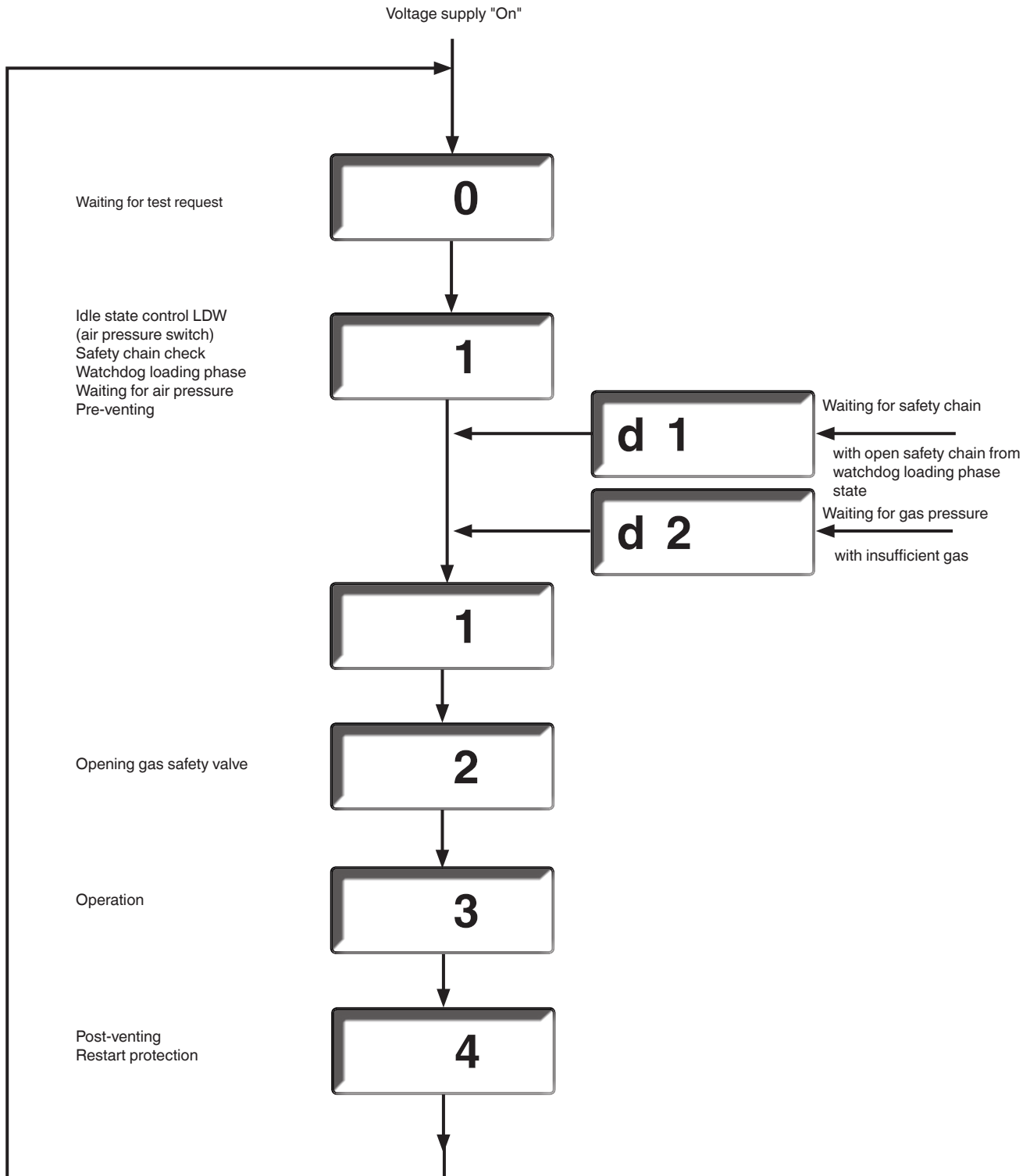

7.4 Info display

- ▶ The information display is activated out of the operation display (not during automatic parameter setting).
- ▶ The information display allows you to see the flame quality, the resettable runtime meter, the resettable start counter and the switching cycles counter.
- ▶ This mode is quit after 60 seconds due to a timeout if you do not press any key within this time period.

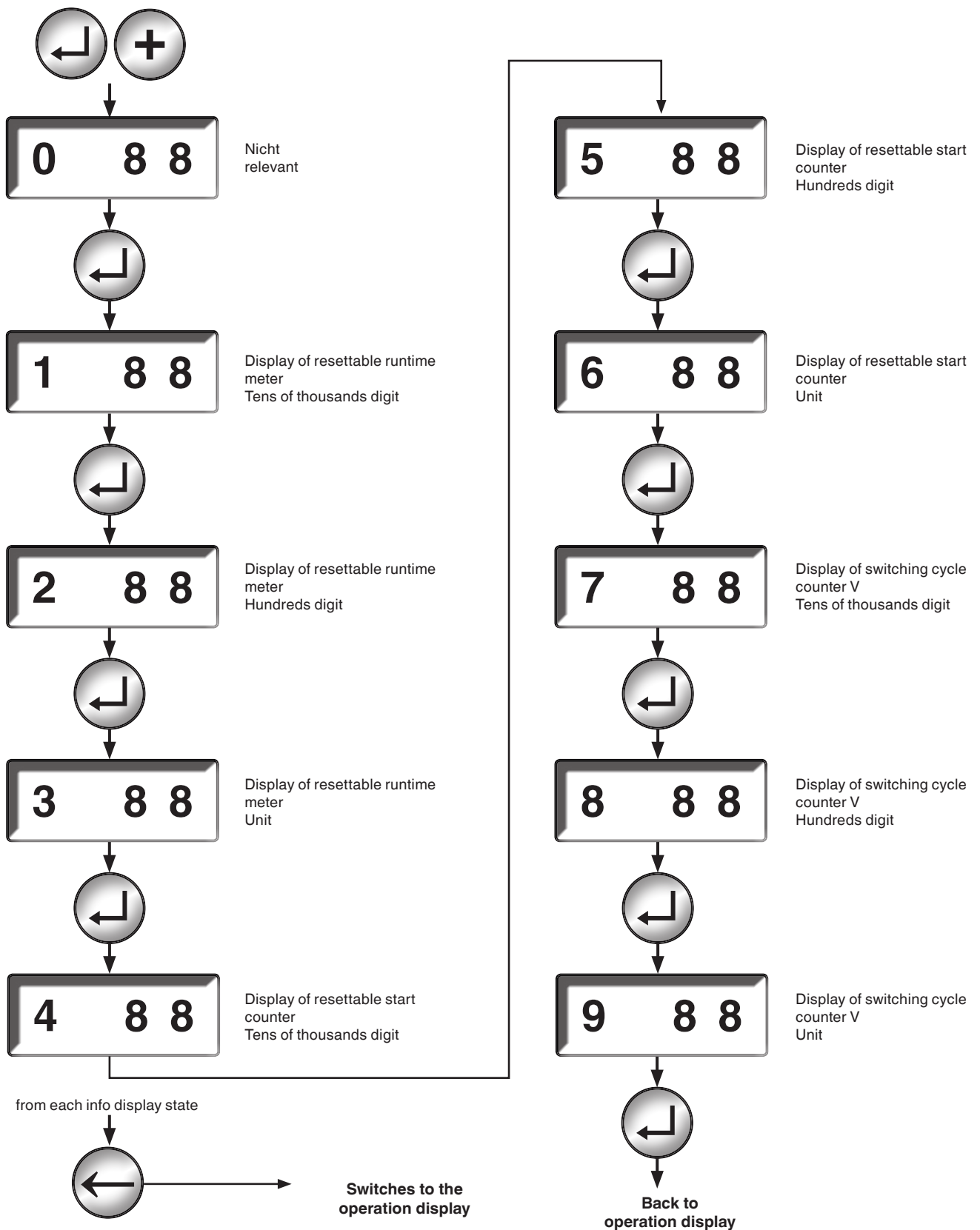

7.5 Error display

► If an error occurs, the error display is activated automatically and the error code is displayed.

Automatic activation
if a fault is active

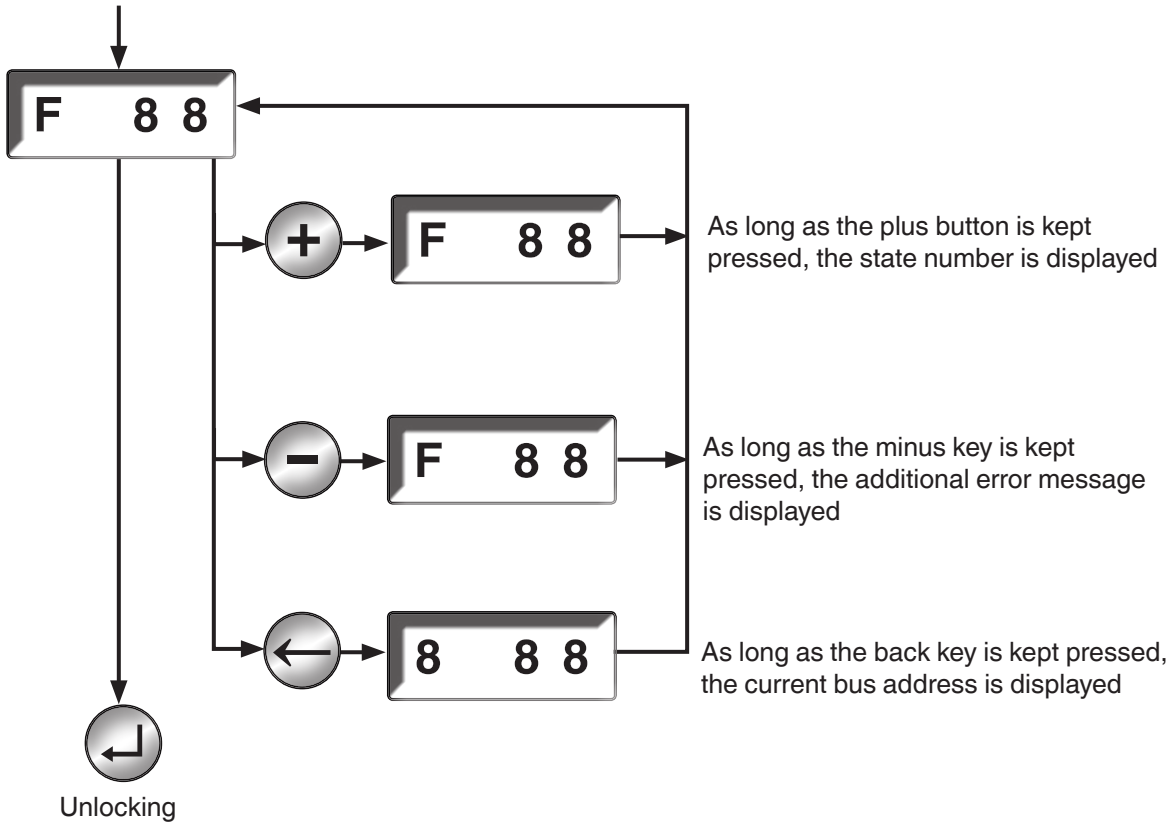

7.6 Error memory display	
▶	The display of the error memory is used to call the last ten errors.
▶	The error that has occurred last is displayed.
▶	The error memory display is activated out of the operational status display
▶	The error code is displayed on the two-digit seven-segment display.
▶	This error memory display is quit after 60 s due to a timeout if you do not press any key within this time period.
▶	If there is not any error for the error position, -- is displayed.

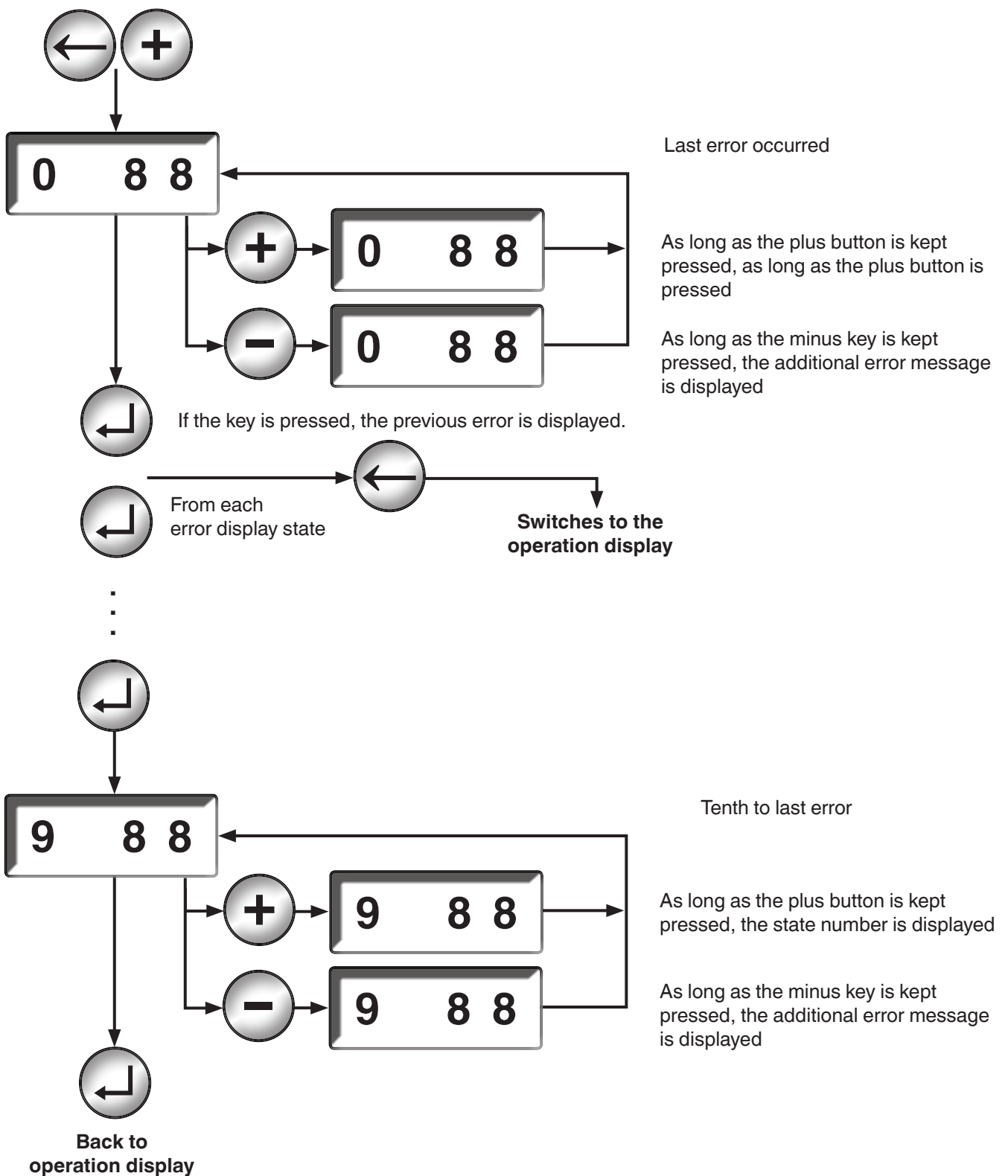

7.7 Error codes

F 04	Unlocking blocked (see Unlocking function)
F 11	Low voltage
F 12	Power failure
F 13	Error watchdog / safety chain not potential-free
F A2	Safety chain interrupted
F A5	Error feedback valve V wrong
F AA	Error idle state control air pressure switch
F Ab	No air pressure
F Ad	Lack of gas
F bF	Safety chain not potential-free

8. Unlocking function

- To unlock the MPA, press the RESET key or external fault clearance key (mains voltage).
- The key must be kept pressed at least 0.5 s and maximum 5 s.
 - In accordance with DIN EN 14459 (Annex J), the number of possible unlocking operations is limited to five in 15 minutes.
 - This means that after more than 5 unlocking attempts within a short time period, the automatic control system will ignore further unlocking operations.
 - Only after a waiting time during which the MPA is provided with power, the MPA can be unlocked again.
 - The waiting time is 15 minutes or 3 minutes for each unlocking operation.

Extended unlocking

The described limitation to 5 unlocking operations in 15 minutes can be reset by means of "Extended unlocking". To do this, the unlock key must be pressed for at least 5 seconds (max. 10 s) (after 5 seconds, the display will start flashing).

- The "Extended unlocking" is active in all operational states of the MPA, that means that a safety cut-off with restart of the MPA in operation can be carried out via the "Extended unlocking" also in the presence of a flame.
- The Extended unlocking is not possible via the 230V unlocking input!
- Depending on the device, operating and error messages are indicated either by means of LEDs or via a 7-segment display.

9. Technical data of MPA 41xx ECS

Type of protection	MPA 4111 ECS: IP 42 MPA 4112 ECS: IP 54 MPA 4122 ECS: IP 65 (Attention: use suitable cable screw connections)
	-20 °C ... +70 °C
Storage and transport	-40 °C ... +80 °C
Humidity	DIN 60730-1, no dewing admissible
Service life of the switching outputs	Minimum 250,000 switching operations
Dimensions of MPA 411x in mm	MPA 4111 ECS (LxHxD): approx.: 152.5 x 148.5 x 77 mm MPA 4112 ECS (LxHxD): approx.: 152.5 x 151.5 x 77 mm
Dimensions of MPA 4122 in mm	MPA 4112 ECS (LxHxD): approx.: 160 x 240 x 80 mm
Rated voltage	230 VAC -15 % ... +10 % or 115 VAC -15 % ... +10 %
Frequency	50 Hz ... 60 Hz
Fuse	6.3 A slow-blow fuse or 10 A fast-blow fuse, integrated, exchangeable
Isolation	No galvanic isolation between mains and 24 VDC or 5 VDC
Electrical connection	Correct (!) phase connection and protective earth conductor according to the wiring diagram
Power consumption (own consumption)	Maximum 10 VA typical: 115 V 230 V Standby: 1.5 W 1.8 W Operation: 3.4 W 4.8 W
Mounting position	As desired

Output	Safety-relevant	Type of output	Line length	Electrical data
V safety gas valve	x	Relay contact	Max. 100 m	115/230 VAC / 2 A cos φ = 1 Minimum load 0.5 W
Fan	-	Relay contact	Max. 100 m	115/230 VAC / 1 A cos φ = 0.4 corresponds to 115/230 VAC / 2.5 A cos φ = 1
Operation	-	Relay contact	Max. 100 m	115/230 VAC / 1 A cos φ = 1
Fault	-	Relay contact	Max. 100 m	115/230 VAC / 1 A cos φ = 1

The sum of the currents of all safety-relevant consumers must not exceed 5 A!

The sum of the currents of all consumers must not exceed 6.3 A (10 A).

Input	Type of input	Line length	Electrical data
Safety chain	Potential-free contact	Max. 100 m	115/230 VAC / max. 10 A
Gas pressure switch	Switching contact	Max. 100 m	115/230 VAC
Test request	Switching contact	Max. 100 m	115/230 VAC
Air pressure switch	Switching contact	Max. 100 m	115/230 VAC
Remote unlocking	Switching contact	Max. 100 m	115/230 VAC

10. Electrical connection

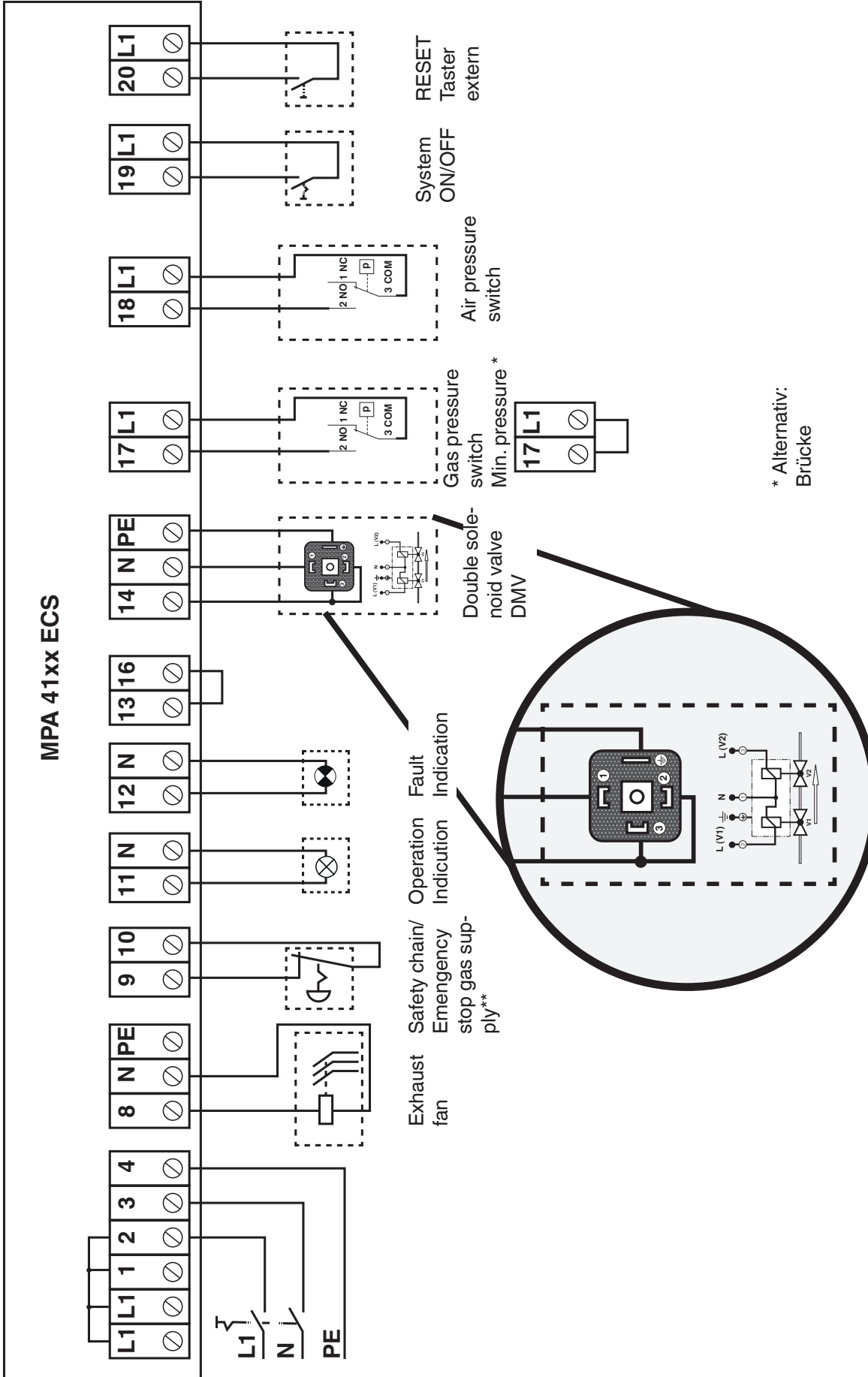

*If the gas pressure switch is not connected to terminal 17, terminal 17 must be connected to L1.

**If no safety shut off devices are required a short cut wire (min. 0,75 mm²) has to be installed between Pin 9 and 10.

10. Electrical connection

Attention:
MPA 411x ECS version

After having removed the hood, you might get in contact with the electrical connections in the terminal socket. Risk of fatal electric shocks! Therefore, you must interrupt the power supply before removing the hood.

Do not remove the jumper between terminals 1 and 2, which was mounted in the factory. It is required for the intended use of the automatic gas burner control system.

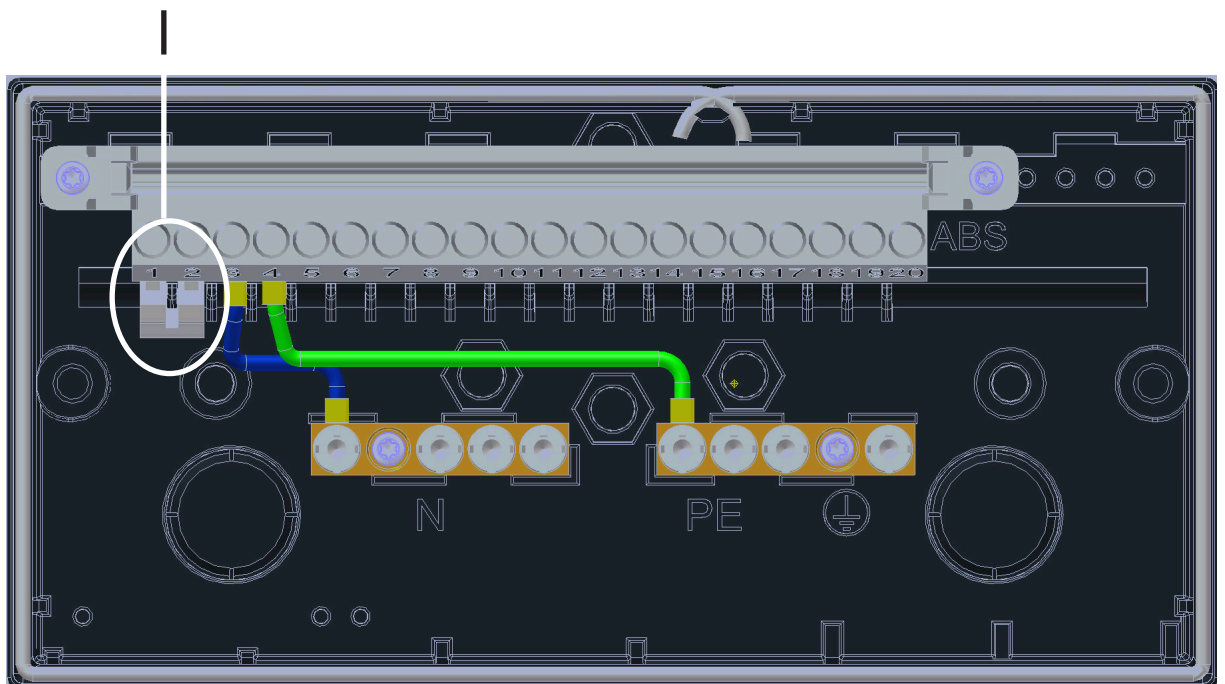

Attention:
MPA 412x ECS version

After the housing is opened, you might get in contact with the electrical connections in the terminal socket. Risk of fatal electric shocks! Therefore, you must interrupt the power supply before removing the hood.

11. Installation of MPA 41xx ECS

Installation options for the MPA 41xx EC:

- Screwing the base directly to the installation surface
Break off installation holes using, for example, a suitable screwdriver or bore them using a drill 4.2 mm (M4) or 5.5 mm (M5).
- Hat rail mounting (locking the base into place on a hat rail)

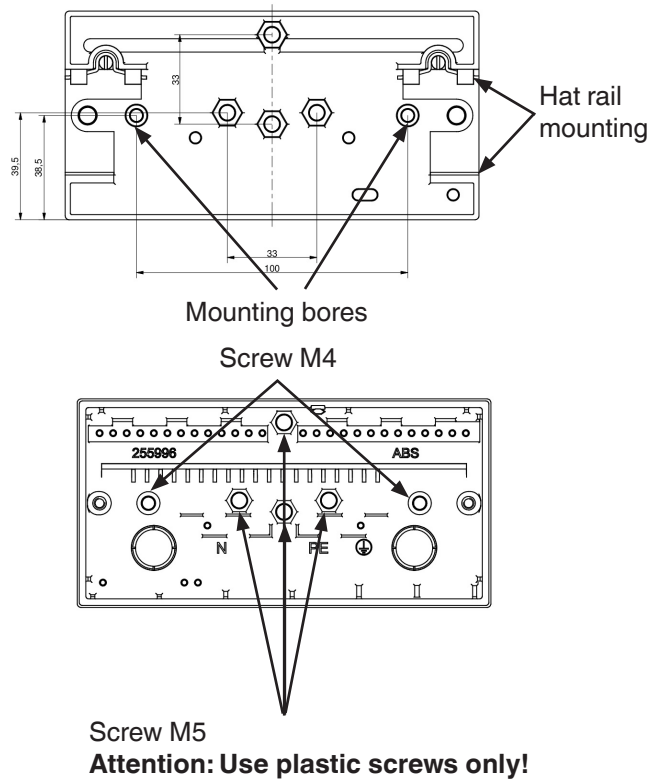

Dimensions [mm] MPA 4111 ECS

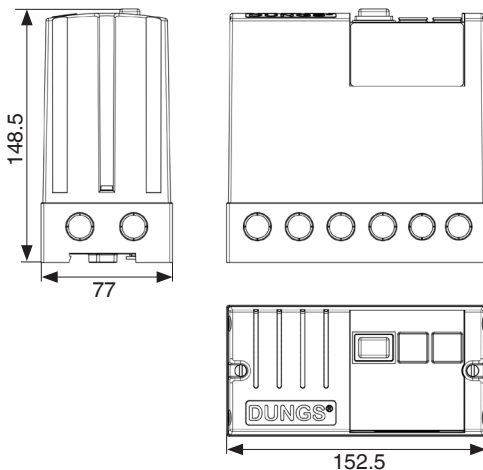

MPA 4112 ECS

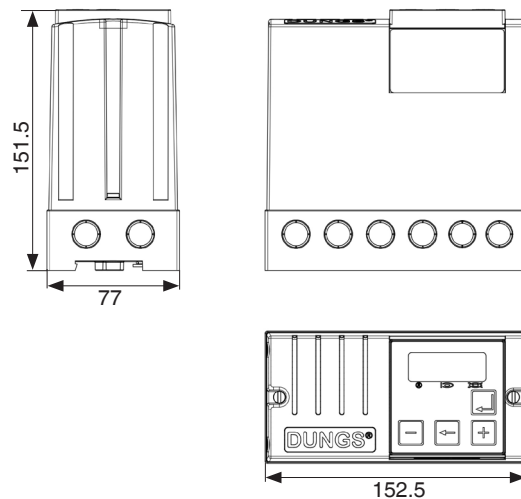

11. Installation of MPA 41xx ECS

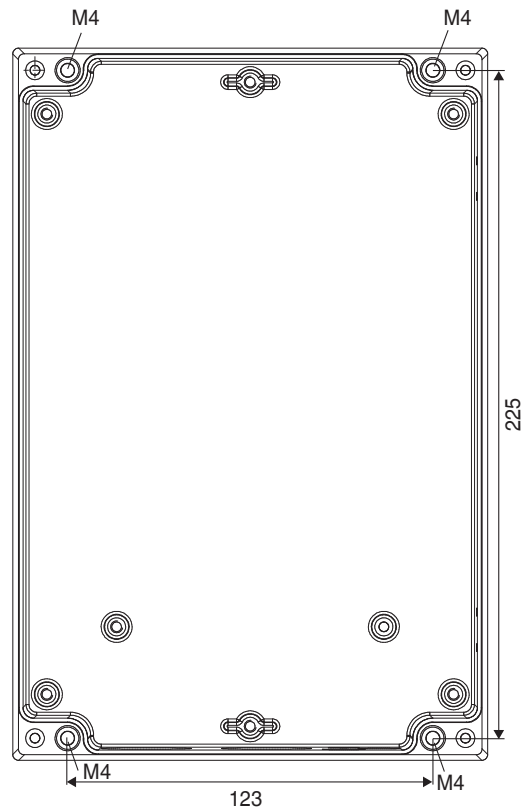

MPA 412x ECS
Installation options:

- Direct screw connection of the housing to the installation surface using M4 screws, length min. 20 mm

MPA 412x ECS dimensions

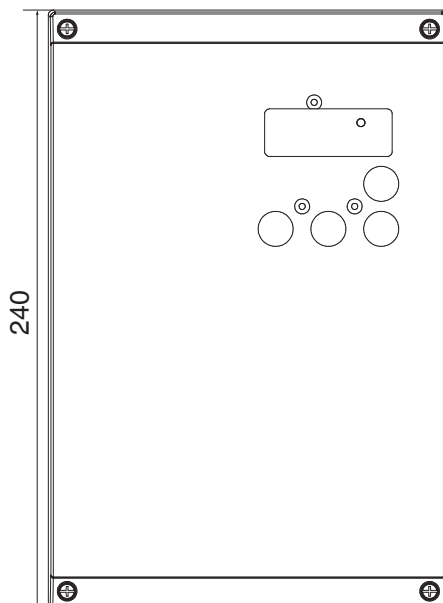
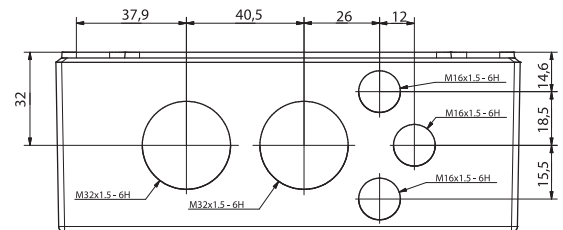
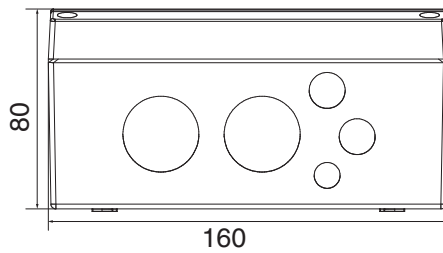

12. Function test, regular maintenance and periodical checks

Observe the requirements of technical rules DVGW worksheet G631 (A) (German Technical and Scientific Association of Gas and Water) for commissioning and periodical checks of the system.

After the installation of MPA 41xx ECS system, check the function of the entire system before transfer to the operator.

The check is performed by the contractual installation company. The designated function of the system must be documented.

In particular during mounting and positioning of the air pressure switch make sure to avoid damage or soiling. The switch-off point has to be selected in such a way that the gas supply is enabled only if sufficient extraction for all operating states is ensured.

During the initial commissioning or within the scope of periodical checks of the system, any possible operating states must be checked or simulated.

1. Function test during operation of all gas devices

The function of the exhaust air system has to be checked, flawless extraction must be ensured.

2. Function test during reduction of the extraction until shortly before the switch-off point

The function of the exhaust air system has to be checked, flawless extraction must be ensured.

3. Function test in case of extraction failure during operation

A failure can occur due to misadjustment of the air pressure switch, disconnection of a connection hose to the air pressure switch or interruption of the voltage supply for the exhaust air fan.

Each fault must lead to a fault switch-off with locking.

4. Check of the unlocking time

After the gas valves have been closed due to an error of the extraction system, ensure that locking of the system is possible only with sufficient delay time. Check and make sure that the flame monitoring systems are closed before repeated opening of the gas supply.

5. Periodical checks

After checking the entire system, the contractual installation company must instruct the operator on the function and proper operation.

In particular the operator's attention must be drawn to the duty to perform regular checks of the system.

These checks are to be performed and documented periodically within the scope of the exhaust lines check as well as after repair and maintenance work (also see DVGW G631 (A), section 5.2.8).

13. System Accessories

1. Gas shutting-off device	DUNGS double solenoid valve DMV tested according to DIN EN 161. Unit manufacturer-assembled with TAS / ball valve combination See DUNGS data sheet No. 7.30
2. Air pressure switches	DUNGS Differential pressure switches KS A2-7 Climate Set See DUNGS data sheet No. 5.21
3. Gas pressure switch	DUNGS Gas pressure switches for monitoring the supply gas pressure. Can be used optionally, also pre-mounted on the DMV double solenoid valve See DUNGS data sheet No. 5.02



The Pressure Equipment Directive (PED) and the Energy Performance for Buildings Directive (EPBD) require the **heating installations to be checked at regular intervals to ensure high long-term utilization ratios, resulting in minimum environmental impact.**

It is necessary to exchange safety-related components after the end of their service life. This recommendation applies only to heating installations and not to thermal process installations. DUNGS recommends to exchange them according to the following table:

Safety-relevant component	SERVICE LIFE DUNGS recommends replacing them after:	Operating cycles
Valve proving systems	10 years	250,000
Pressure switches	10 years	N/A
Automatic burner with flame safeguard	10 years	250,000
Flame detectors (UV probes)	10,000 h operating hours	
Gas pressure regulators	15 years	N/A
Gas valve with valve proving system	After having detected an error	
Gas valve without valve proving system*	10 years	250,000
Min. gas pressure switch	10 years	N/A
Safety relief valve	10 years	N/A
Gas/air compound systems	10 years	N/A
* Gas families I, II, III N/A cannot be used		

We reserve the right to make modifications in the course of technical development.

Company address
Karl Dungs GmbH & Co. KG
Siemensstr. 6-10
D-73660 Urbach, Germany
Phone +49 (0)7181-804-0
Fax +49 (0)7181-804-166
info@dungs.com
www.dungs.com