

**AUTOMATIC GAS VALVES Fast Opening / Fast Closing
DN65, DN80, DN100 – Pmax 360 mbar - 6 bar**



| Code | Description | Dimension | Pmax |
|--------------------|----------------------------------------|-----------|----------|
| AVD65FO | Gas valve fast opening | DN65 | 360 mbar |
| AVD80FO | Gas valve fast opening | DN80 | 360 mbar |
| AVD100FO | Gas valve fast opening | DN100 | 360 mbar |
| AVD65FO-FR | Gas valve fast opening Flow regulation | DN65 | 360 mbar |
| AVD80FO-FR | Gas valve fast opening Flow regulation | DN80 | 360 mbar |
| AVD100FO-FR | Gas valve fast opening Flow regulation | DN100 | 360 mbar |
| AVD65FO-6B | Gas valve fast opening | DN65 | 6 bar |
| AVD80FO-6B | Gas valve fast opening | DN80 | 6 bar |
| AVD100FO-6B | Gas valve fast opening | DN100 | 6 bar |

TECHNICAL FEATURES

| | |
|------------------------------------------------|----------------------------------------------------------------------------------|
| Pmax | 360 mbar - 6 bar |
| Inlet connection | Flanged – DN65 – DN80 – DN100 – PN16 |
| Outlet | Flanged – DN65 – DN80 – DN100 – PN16 |
| Opening time | <1 second |
| Closing time | <1 second |
| Max number of operations | 20 per minute |
| Incorporated AISI 303 steel mesh filter | |
| Supply voltage | 230V (-15%+10%) 50-60Hz. 110V (-15%+10%) 50-60Hz. 24Vdc (-15%+10%) 50-60Hz |
| Power | DN65 - DN 80 68 VA - DN100 170 VA Coils to class F copper wire class H |
| Use | Non – aggressive gases – Family 1 – 2 – 3 and air |
| Test point | Screw ¼" NPT |
| CPI | On request |
| Working Temperature | - 20 °C – 60 °C |
| Approval | EN161 |
| Protection degree | IP65 |

Materials:

Complete Body Die – Cast Aluminium Gd – AISI12Cu - EN AB 46100

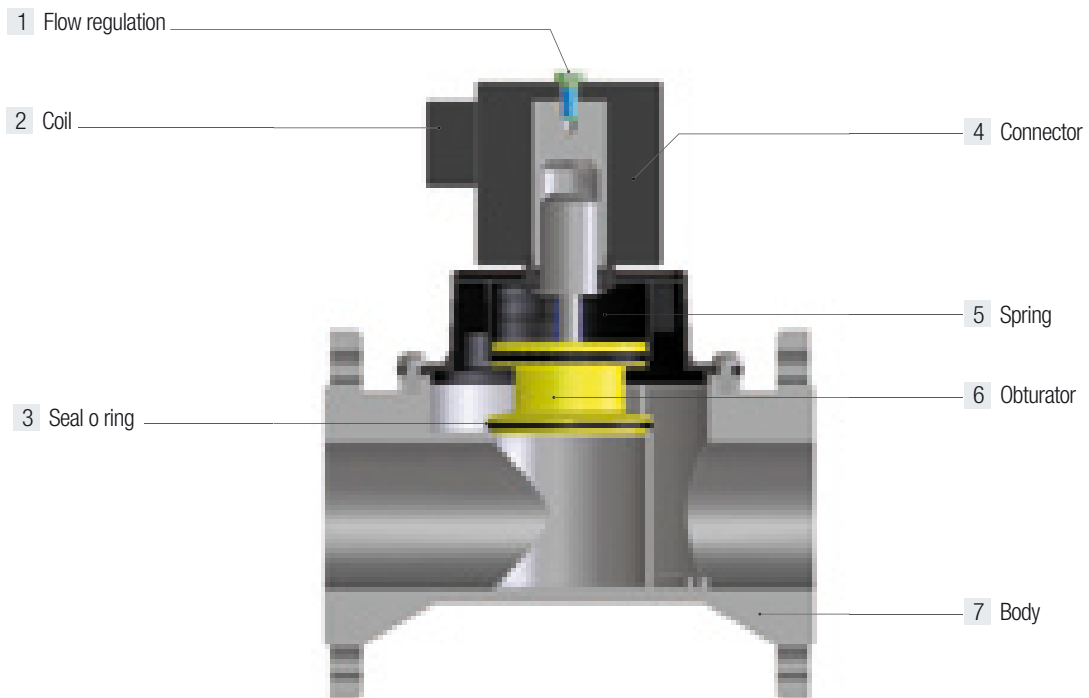

FLOW CHART

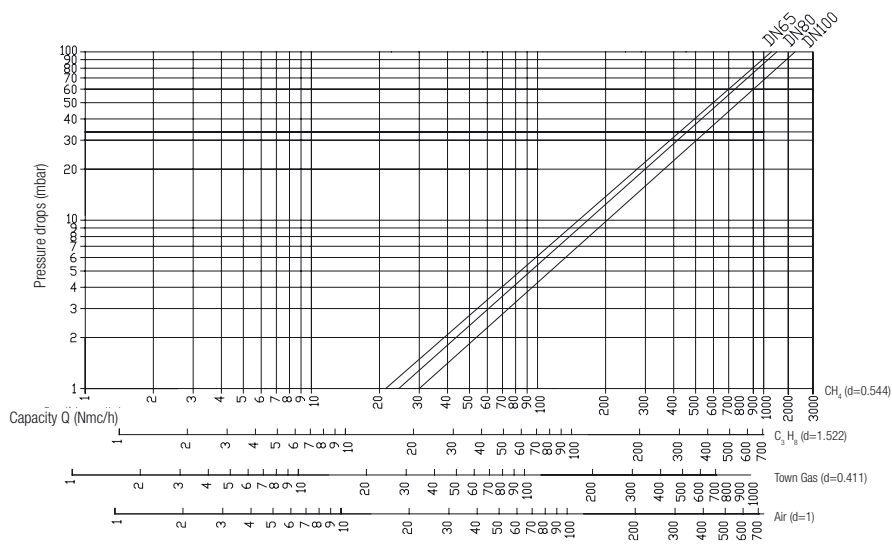

| DIMENSIONS (mm) and WEIGHT (kgs) | | | |
|----------------------------------|-----|-----|-----|
| Dimension | A | B | C |
| DN65 | 340 | 185 | 240 |
| DN80 | 340 | 200 | 265 |
| DN100 | 350 | 220 | 265 |

