

**Betriebs- und Montageanleitung**

**Operation and assembly instructions**

**Notice d'emploi et de montage**

**Istruzioni di esercizio di montaggio**

**Magnetventil einstufige Betriebsweise**

Typ MV .../4  
Typ MVD .../5  
Typ MVDLE .../5  
Nennweiten  
Rp 3/8 – Rp 2 1/2  
DN 20 – DN 100

**Solenoid valve one stage operation**

Type MV .../4  
Type MVD .../5  
Type MVDLE .../5  
Nominal diameters  
Rp 3/8 – Rp 2 1/2  
DN 20 – DN 100

**Electrovanne de sécurité à une allure**

Type MV .../4  
Type MVD .../5  
Type MVDLE .../5  
Diamètres nominaux  
Rp 3/8 – Rp 2 1/2  
DN 20 – DN 100

**Valvole elettromagnetiche monostadio**

Tipo MV .../4  
Tipo MVD .../5  
Tipo MVDLE .../5  
Diametri nominali  
Rp 3/8 – Rp 2 1/2  
DN 20 – DN 100

**Einbaulage  
Installation position  
Position de montage  
Posizione di montaggio**

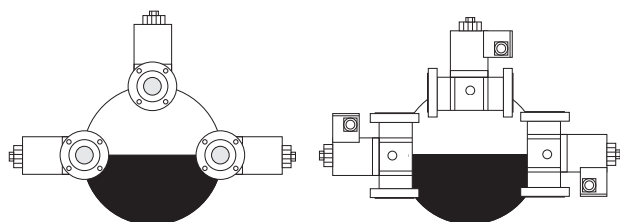

**Elektrischer Anschluß  
Electrical connection  
Raccordement électrique  
Allacciamento elettrico  
IEC 730-1 (VDE 0631 T1)**

Erdung nach örtlichen Vorschriften  
Grounding acc. local regulations  
Mise à la terre selon normes locales  
Messa a terra secondo prescrizioni locali

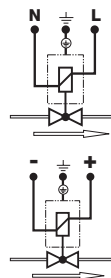

AC

DC

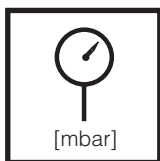
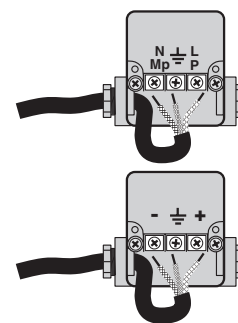

[mbar]

Max. Betriebsdruck  
Max. operating pressure  
Pression de service maxi.  
Max. pressione di esercizio  
MV ... 2.../4 p<sub>max.</sub> = 200 mbar (20 kPa)  
MV ... 2.../5 p<sub>max.</sub> = 200/360 mbar (20/36 kPa)  
MV ... 5.../5 p<sub>max.</sub> = 500 mbar (50 kPa)

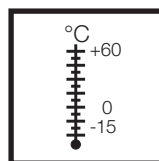

+60  
0  
-15

Umgebungstemperatur  
Ambient temperature  
Température ambiante  
Temperatura ambiente  
-15 °C ... +60 °C



EN 161

**Klasse A, Gruppe 2**  
**Class A, Group 2**  
**Classe A, Groupe 2**  
**Class A, Gruppo 2**  
nach / acc. / selon / a norme  
EN 161



IEC 529

Schutzart/Degree of protection  
Protection/Protezione  
**IP 54** nach / acc. / selon / a norme  
**IEC 529 (DIN EN 60529)**  
Optional/Optional/Optional/Opti-  
onal IP 65

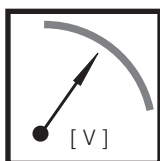

[V]

U<sub>n</sub> ~(AC) 230 V -15 % +10 %  
oder/or/ou/o  
~(AC) 110 V-120V, ~(AC) 240 V  
=(DC) 48 V, =(DC) 24 V- 28V  
Einschaltdauer/Switch-on duration/  
Durée de mise sous tension/ Durata  
inserzione **100 %**

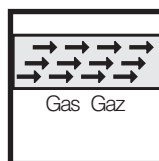

Gas Gaz

Familie 1 + 2 + 3  
Family 1 + 2 + 3  
Famille 1 + 2 + 3  
Famiglia 1 + 2 + 3

**Druckabgriffe / Pressure taps  
Prises de pression / Manopola a pressione**

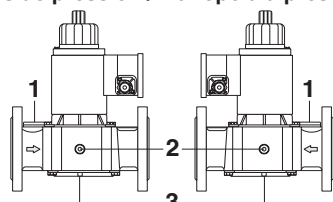

**1**  
nur Flanschausführung ab DN 25  
**Only** flange version from DN 25  
**Uniquement** version à bride à partir  
de DN 25  
**Solo** esecuzione flangia da DN 25  
Verschlußschraube  
Sealing plug  
Bouchon fileté  
Vite di chiusura  
G 3/4 DIN ISO 228

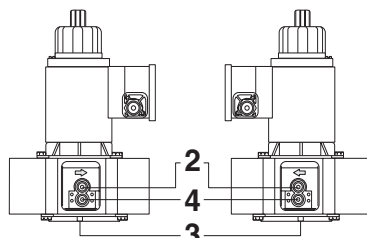

**2**  
Verschlußschraube  
Sealing plug  
Bouchon fileté  
Vite di chiusura  
G 1/4 DIN ISO 228

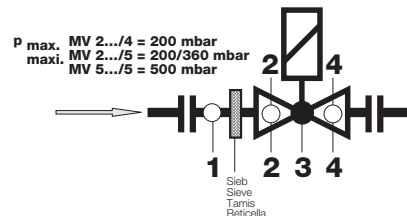

P<sub>max.</sub> MV 2.../4 = 200 mbar  
maxi. MV 2.../5 = 200/360 mbar  
MV 5.../5 = 500 mbar

**3**  
Anschlußmöglichkeit für Endkon-  
takt/Connection for C.P.I./Possibili-  
té da raccordement pour contact de  
fin de course/Possibilita' di attacco  
per finecorsa: **K01/1**  
Verschlußschraube / Sealing plug/  
Bouchon fileté / Vite di chiusura  
G 1/8 DIN ISO 228

**4**  
Rp 1/2 – Rp 2  
**nur** Gewindeausführung  
**Only** threaded version  
**Uniquement** version filettée  
**Solo** esecuzione filettata  
Bypassbohrung unter Verschlußde-  
ckel, optional / Bypass port under  
cover, optional / Perçage de dérivati-  
on sous couvercle / Foro per bypass  
sotto il coperchietto, otional.

MV 2.../4 nur Druckabgriff 2 / only pressure tap 2 / uniquement prise de pression 2 / solo manopola a pressione 2

Typ Type Type Tipo	p <sub>max.</sub>	DN / Rp	Magnet-Nr. Solenoid-No. N° bobine Bobina no.	P <sub>max.</sub> [VA]	I <sub>max.</sub> ~(AC) 230 V	Öffnungszeit Opening time Durée d'ouverture Tempo apertura	Einbaumaße / Dimensions / Cotes d'encombrement / Dimensioni [mm]						Gewicht Weight Poids Peso [kg]	
							a	b	c	d	e	f		g
							MV 205/4	200	Rp 1/2	100	17	0,08		< 1 s
MV 207/4	200	Rp 3/4	200	30	0,15	< 1 s	75	100	135	85	160	200	25	1,75
MV 210/4	200	Rp 1	200	30	0,15	< 1 s	75	110	135	90	165	200	30	2,45
MV 215/4	200	Rp 1 1/2	300	65	0,26	< 1 s	95	150	170	116	215	260	45	4,30
MV 220/4	200	Rp 2	300	65	0,30	< 1 s	95	170	175	130	225	265	50	5,90
MVD 203/5	360	Rp 3/8	100	17	0,08	< 1 s	50	60	90	60	113	140	23	0,85
MVD 205/5	360	Rp 1/2	100	17	0,08	< 1 s	50	80	90	75	113	150	23	1,00
MVD 207/5	200	Rp 3/4	150	30	0,13	< 1 s	60	100	135	80	160	190	25	1,75
MVD 207/5	360	Rp 3/4	200	30	0,15	< 1 s	75	100	135	85	160	200	25	2,40
MVD 210/5	360	Rp 1	200	30	0,15	< 1 s	75	110	135	90	165	200	30	2,45
MVD 215/5	200	Rp 1 1/2	280	60	0,26	< 1 s	80	150	170	116	215	255	45	4,30
MVD 215/5	360	Rp 1 1/2	300	65	0,30	< 1 s	95	150	170	116	215	260	45	5,40
MVD 220/5	200	Rp 2	300	65	0,30	< 1 s	95	170	175	130	225	265	50	5,90
MVD 225/5	200	Rp 2 1/2	400	100	0,48	< 1 s	115	230	220	165	280	325	55	10,90
MVDLE 203/5	360	Rp 3/8	100	17	0,08	ca. 20 s	50	60	135	75	155	190	20	0,95
MVDLE 205/5	360	Rp 1/2	100	17	0,08	ca. 20 s	50	80	135	75	155	200	20	1,10
MVDLE 207/5	360	Rp 3/4	200	30	0,15	ca. 20 s	75	100	165	85	190	190	25	2,55
MVDLE 210/5	360	Rp 1	200	30	0,13	ca. 20 s	75	110	165	90	200	190	25	2,75
MVDLE 215/5	200	Rp 1 1/2	280	60	0,26	ca. 20 s	80	150	205	116	245	255	40	4,40
MVDLE 215/5	360	Rp 1 1/2	300	65	0,30	ca. 20 s	95	150	205	116	245	255	40	5,50
MVDLE 220/5	200	Rp 2	300	65	0,26	ca. 20 s	95	170	205	130	250	255	45	6,20
MVDLE 225/5	200	Rp 2 1/2	400	100	0,48	ca. 20 s	115	230	295	165	350	320	55	11,40
MVD 503/5	500	Rp 3/8	100	17	0,08	< 1 s	50	60	90	60	113	140	23	0,85
MVD 505/5	500	Rp 1/2	100	17	0,08	< 1 s	50	80	90	75	113	150	23	1,00
MVD 507/5	500	Rp 3/4	200	30	0,15	< 1 s	75	100	135	85	160	200	25	2,40
MVD 510/5	500	Rp 1	200	30	0,15	< 1 s	75	110	135	90	165	200	30	2,60
MVD 515/5	500	Rp 1 1/2	300	65	0,30	< 1 s	95	150	170	116	215	260	45	5,40
MVD 520/5	500	Rp 2	400	100	0,48	< 1 s	115	170	190	130	235	300	45	8,80
MVD 525/5	500	Rp 2 1/2	500	90	0,42	< 1 s	130	230	215	165	300	370	55	14,50
MVDLE 503/5	500	Rp 3/8	100	17	0,08	ca. 20 s	50	60	135	75	155	190	20	0,80
MVDLE 505/5	500	Rp 1/2	120	25	0,11	ca. 20 s	50	80	150	75	170	220	20	1,00
MVDLE 507/5	500	Rp 3/4	200	30	0,15	ca. 20 s	75	100	165	85	190	190	25	2,50
MVDLE 510/5	500	Rp 1	250	26	0,12	ca. 20 s	75	110	190	90	220	213	30	2,60
MVDLE 515/5	500	Rp 1 1/2	300	65	0,30	ca. 20 s	95	150	205	116	245	255	40	5,60
MVDLE 520/5	500	Rp 2	400	100	0,48	ca. 20 s	115	170	230	135	270	300	55	11,10
MVD 2040/5	200	DN 40	280	60	0,26	< 1 s	80	200	170	150	235	255	45	6,80
MVD 2040/5	360	DN 40	300	65	0,30	< 1 s	95	200	170	150	235	255	45	7,00
MVD 2050/5	200	DN 50	300	65	0,26	< 1 s	95	230	175	165	245	255	52	7,70
MVD 2065/5	200	DN 65	400	100	0,48	< 1 s	115	290	225	190	315	330	55	12,70
MVD 2080/5	200	DN 80	500	90	0,42	< 1 s	130	310	250	200	340	375	70	18,50
MVD 2100/5	200	DN 100	550	100	0,48	< 1 s	150	350	310	240	410	480	85	31,00
MVDLE 2040/5	200	DN 40	280	60	0,26	ca. 20 s	80	200	205	150	270	255	45	6,90
MVDLE 2040/5	360	DN 40	300	65	0,30	ca. 20 s	95	200	205	150	270	255	45	7,10
MVDLE 2050/5	200	DN 50	300	65	0,26	ca. 20 s	95	230	210	165	280	255	52	7,50
MVDLE 2065/5	200	DN 65	400	100	0,48	ca. 20 s	115	290	290	190	385	330	55	13,30
MVDLE 2080/5	200	DN 80	500	90	0,42	ca. 20 s	130	310	320	200	405	375	70	18,50
MVDLE 2100/5	200	DN 100	550	100	0,48	ca. 20 s	150	350	380	240	480	480	85	31,00
MVD 5040/5	500	DN 40	300	65	0,26	< 1 s	95	200	170	150	235	255	45	7,00
MVD 5050/5	500	DN 50	400	100	0,48	< 1 s	115	230	190	165	265	295	52	12,00
MVD 5065/5	500	DN 65	500	90	0,42	< 1 s	130	290	245	190	340	370	55	17,00
MVD 5080/5	500	DN 80	550	100	0,50	< 1 s	150	310	295	200	385	465	70	27,00
MVD 5100/5	500	DN 100	60E	80	7,5*	< 1 s	170	350	345	240	445	570	85	42,00
MVDLE 5040/5	500	DN 40	300	65	0,26	ca. 20 s	95	200	205	150	270	255	45	7,00
MVDLE 5050/5	500	DN 50	400	100	0,48	ca. 20 s	115	230	230	165	300	295	52	13,10

f = Platzbedarf für Magnetmontage  
Space requirement for mounting solenoid  
Encombrement pour montage de l'aimant  
Ingombro per montaggio bobina

d = größte Breite  
Max. width  
Largeur maxi.  
Larghezza massima

\* = für max. 3 s  
for max. 3 s  
pour max. 3 s  
per max. 3 s

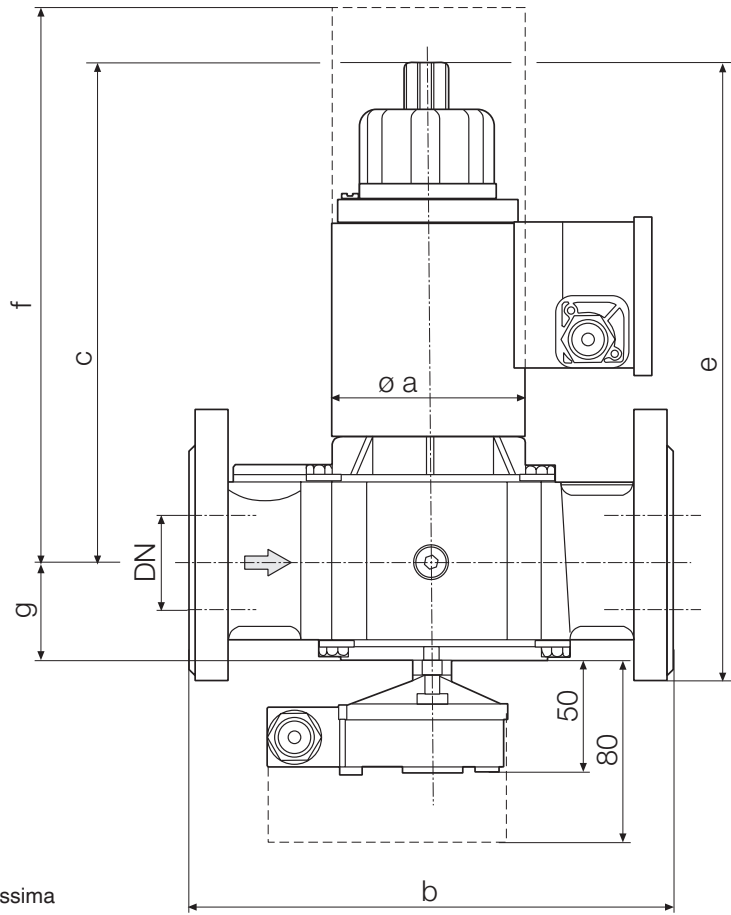

d = größte Breite  
 Max. width  
 Largeur maxi.  
 Larghezza massima

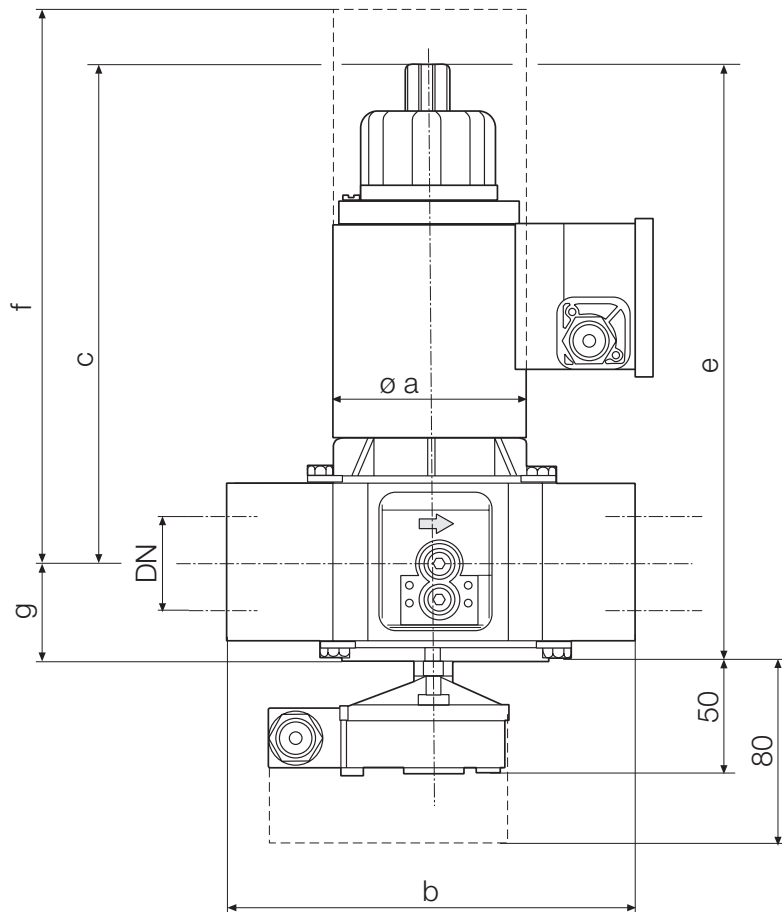

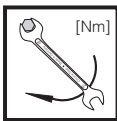

max. Drehmomente / Systemzubehör max. torque / System accessories max. couple / Accessoires du système max. coppie / Accessorio di sistema	M 3	M 4	M 5	M 6	M 8	G 1/8	G 1/4	G 1/2	G 3/4
	0,5 Nm	2,5 Nm	5 Nm	7 Nm	15 Nm	5 Nm	7 Nm	10 Nm	15 Nm

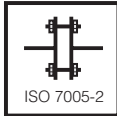

max. Drehmomente / Flanschverbindung max. torque / Flange connection couple maxi. / Joint à brides max. coppie / Collegamento a flangia	M 16 x 65 (DIN 939)	Stiftschraube Setscrew Goujon Vite per acciaio
	50 Nm	



**Geeignetes Werkzeug einsetzen!**  
Please use proper tools!  
Utiliser des outils adaptés!  
Impiegare gli attrezzi adeguati!

**Schrauben kreuzweise anziehen!**  
Tighten screws crosswise!  
Serrer les vis en croisant!  
Stringere le viti incrociate!



Gerät darf nicht als Hebel benutzt werden.  
Do not use unit as lever.  
Ne pas utiliser la vanne comme un levier.  
L'apparechio non deve essere usato come leva.

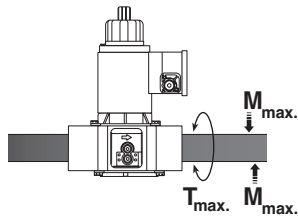

DN	--	--	20	25	40	50	65	80	100
Rp	3/8	1/2	3/4	1 1/2	2	2 1/2	--	--	--
[Nm] t ≤ 10 s									
M <sub>max.</sub>	70	105	225	340	610	1100	1600	2400	5000
[Nm] t ≤ 10 s									
T <sub>max.</sub>	35	50	85	125	200	250	325	400	400

#### Gewindeausführung MV .../4, MV .../5 Einbau

1. Gewinde schneiden.
2. Geeignetes Dichtmittel verwenden, Bild 1.
3. Geeignetes Werkzeug verwenden, Bild 1.
4. Nach Einbau Dichtheits- und Funktionskontrolle.

#### Threaded version MV .../4, MV .../5 Mounting

1. Tap thread.
2. Use suitable sealing agent, refer to Fig. 1.
3. Use suitable tool, refer to Fig. 1.
4. Perform leak and functional tests after mounting.

#### Version fileté MV .../4, MV .../5 Pose

1. Fileter.
2. Employer un produit d'étanchéité approprié, figure 1.
3. Utiliser un outillage adapté, figure 2.
4. Après la pose, effectuer un contrôle d'étanchéité et de fonctionnement.

#### Esecuzione filettata MV .../4, MV .../5 Montaggio

1. Tagliare il filetto
2. Utilizzare adeguate guarnizioni, Fig. 1.
3. Utilizzare adeguate guarnizioni, Fig. 1.
4. Dopo il montaggio effettuare una prova di tenuta e funzionamento.

#### Flanschausführung MV .../5 Einbau

1. Stiftschrauben unten einsetzen.
2. Dichtung einsetzen.
3. Stiftschrauben oben einsetzen.
4. Stiftschrauben festziehen. Drehmomentetabelle beachten!  
**Auf korrekten Sitz der Dichtung achten!**
5. Nach Einbau Dichtheits- und Funktionskontrolle.

#### Flange version MV .../5 Mounting

1. Insert bottom setscrews.
2. Insert seal.
3. Insert top setscrews.
4. Tighten setscrews. Refer to torque table.  
**Make sure that the seal is seated correctly.**
5. Perform a leakage and functional test after installation.

#### Version à bride MV .../5 Pose

1. Mettre en place les goujons inférieurs.
2. Mettre le joint d'étanchéité en place.
3. Mettre en place les goujons supérieurs.
4. Serrer les goujons. Respecter le tableau des couples.  
**Veiller à ce que le joint d'étanchéité soit placé correctement!**
5. Après le montage, contrôler l'étanchéité et le fonctionnement.

#### Esecuzione flangiata MV .../5 Montaggio

1. Montare le viti per acciaio in basso.
2. Mettere la guarnizione.
3. Montare le viti per acciaio in alto.
4. Serrare le viti attenendosi alle coppie di serraggio indicate nella tabella!  
**Posizionare la guarnizione in modo giusto!**
5. Dopo il montaggio effettuare un controllo funzionale e di tenuta.

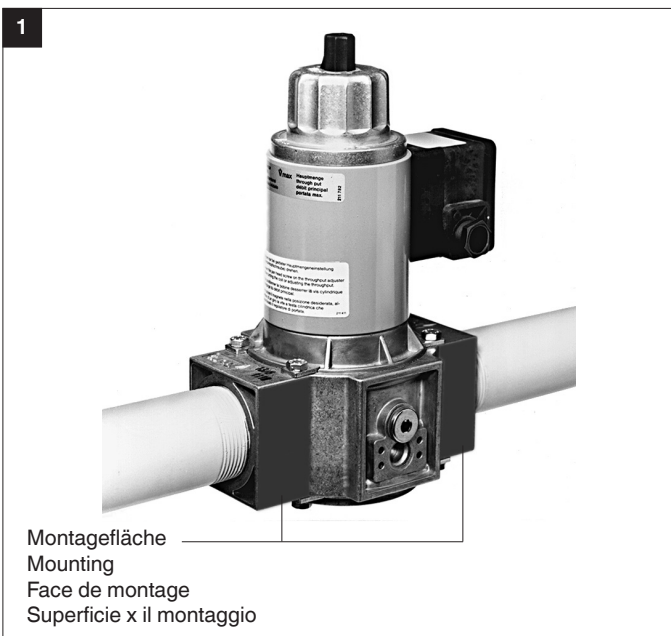

**MVD .../5**  
**Hauptmengeneinstellung**  
**Setting the main flow**  
**Réglage du débit principal**  
**Regolazione portata principale**

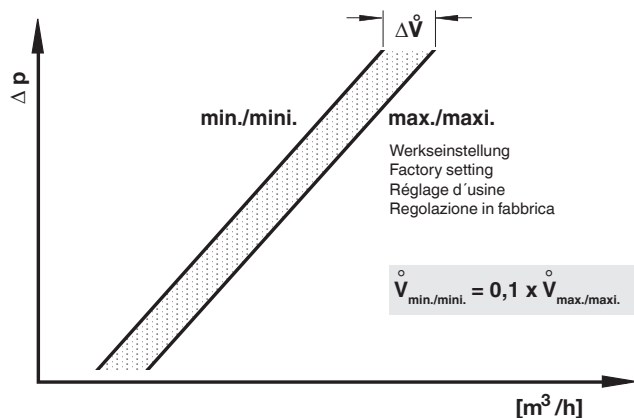
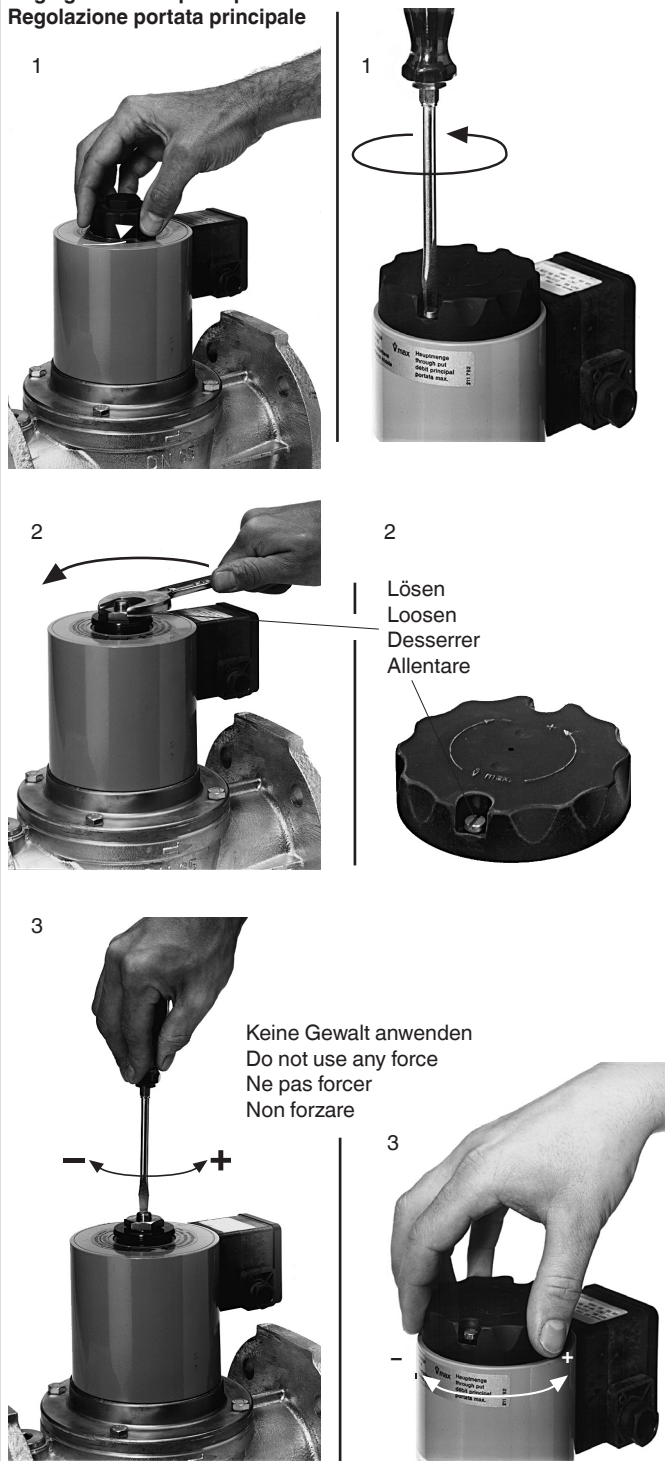

**MVDLE .../5**  
**Hauptmengeneinstellung**  
**Setting the main flow**  
**Réglage du débit principal**  
**Regolazione portata principale**



**MVDLE .../5**  
**SchnellhubEinstellung Vstart**

Werkseinstellung MVDLE .../5:  
 Schnellhub nicht eingestellt

1. Einstellkappe E von der Hydraulik abschrauben.
2. Einstellkappe drehen und als Werkzeug benutzen.
3. Linksdrehen = Vergrößerung des Schnellhubes (+).

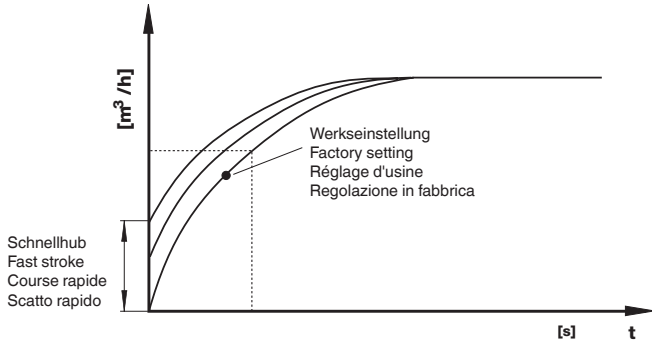

**MVDLE .../5**  
**Rapid stroke adjustment V start**

Factory setting MVDLE .../5:  
 Rapid stroke not adjusted

1. Unscrew the adjustment cap E from the hydraulic brake.
2. Invert the adjustment cap and use as a tool.
3. Turn anti-clockwise = increase rapid stroke (+).

**MVDLE .../5**  
**Réglage course rapide V start**

Réglage en usine MVDLE .../5:  
 Course rapide non réglée

1. Dévisser le capuchon de réglage E du frein hydraulique
2. Tourner le capuchon de réglage et l'utiliser comme outil.
3. Rotation à gauche = augmentation de la course rapide (+).

**MVDLE .../5**  
**Regolazione scatto rapido Vstart**

Regolazione in fabbrica del MVDLE .../5: Scatto rapido non regolato

1. Svitare dall'idraulico la farfalla E.
2. Fare ruotare la valvola a farfalla utilizzandola come attrezzo.
3. Rotazione antioraria = aumento dello scatto rapido (+).

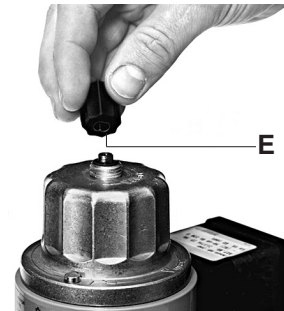

**Austausch Hydraulik oder Einstellteller**

1. Anlage ausschalten.
2. Sicherungslack über der Senkkopfschraube A entfernen.
3. Senkkopfschraube A ausschrauben.
4. Zylinderkopfschraube B ausschrauben.
5. Einstellteller C bzw. Hydraulik D abheben.
6. Einstellteller C bzw. Hydraulik D austauschen.
7. Senk- und Zylinderkopfschraube wieder eindrehen. Senkkopfschraube nur so festziehen, daß Einstellteller C bzw. Hydraulik D noch gedreht werden kann.
8. Senkkopfschraube A mit Sicherungslack überziehen.
9. **Dichtheitsprüfung über Druckabgriff Verschlußschraube 2:**  
 MVD 2 ... $p_{max.} = 200$  mbar  
 MVD 5 ... $p_{max.} = 500$  mbar
10. Funktionskontrolle durchführen.
11. Anlage einschalten

**Replacing hydraulic brake unit or adjustment plate**

1. Switch off firing system.
2. Remove locking varnish from countersunk screw A.
3. Unscrew countersunk screw A.
4. Unscrew socket head screw B.
5. Raise adjustment plate C or hydraulic brake D.
6. Exchange adjustment plate C or hydraulic brake D
7. Screw in countersunk and socket head screw. Only tighten socket head screw so that adjustment plate C or hydraulic brake D can just be turned.
8. Coat countersunk screw A with locking varnish.
9. **Leakage test: Pressure tap at sealing plug 2:**  
 MVD 2 ... $p_{max.} = 200$  mbar  
 MVD 5 ... $p_{max.} = 500$  mbar
10. Perform functional test.
11. Switch on firing system.

**Remplacement du frein hydraulique ou du disque de réglage**

1. Mettre l'installation hors tension.
2. Eliminer le vernis de blocage au dessus de la vis à tête fraisée A.
3. Dévisser la vis à tête fraisée A.
4. Dévisser la vis à tête cylindrique B.
5. Soulever le disque de réglage C ou le frein hydraulique D.
6. Remplacer le disque de réglage C ou le frein hydraulique D.
7. Revisser les vis à tête fraisée et à tête cylindrique. Serrer la vis à tête fraisée jusqu'à un point où l'on peut encore faire tourner le disque de réglage C ou le frein hydraulique D.
8. Enduire la vis à tête fraisée A de vernis de blocage.
9. **Contrôle d'étanchéité via la prise de pression bouchon fileté 2:**  
 MVD 2 ... $p_{max.} = 200$  mbar  
 MVD 5 ... $p_{max.} = 500$  mbar
10. Procéder à un contrôle de fonctionnement.
11. Mettre l'installation sous tension.

**Sostituzione dell'idraulico o del piattello di regolazione**

1. Disinserire l'impianto
2. Rimuovere la lacca di sigillo sopra la vite a testa svasata A.
3. Svitare la vite a testa svasata A.
4. Svitare la vite a testa cilindrica B.
5. Sollevare il piattello C o l'idraulico D.
6. Sostituire il piattello C o l'idraulico D.
7. Riavvitare la vite a testa cilindrica e stringere la vite a testa svasata soltanto fino a che il piattello C o l'idraulico D possa ancora essere fatto ruotare.
8. Sigillare con la lacca la vite a testa svasata A.
9. **Prova di tenuta attraverso il tappo a su presa di pressione 2:**  
 MVD 2 ... $p_{max.} = 200$  mbar  
 MVD 5 ... $p_{max.} = 500$  mbar
10. Effettuare la prova di funzionamento.
11. Reinserrire l'impianto.

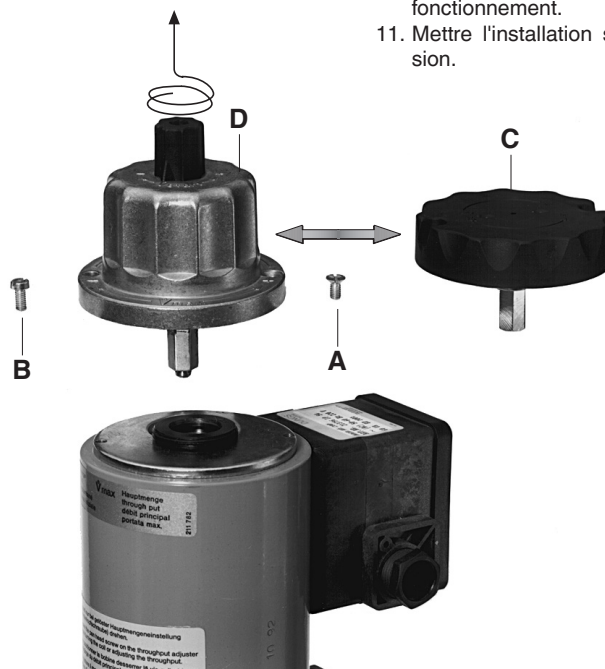

**Magnetwechsel MV .../5**

1. Hydraulik bzw. Einstellteller entfernen, wie auf Seite 6 "Austausch Hydraulik oder Einstellteller", Punkt 1 - 5, beschrieben.
2. Magnet auswechseln.  
**Magnet-Nr. und Spannung unbedingt beachten!**
3. Hydraulik bzw. Einstellteller wieder montieren, wie auf Seite 6 "Austausch Hydraulik oder Einstellteller", Punkt 7 - 11, beschrieben.

**Changing solenoid MV .../5**

1. Remove hydraulic brake unit or adjustment plate as described in Section "Replacing hydraulic brake unit or adjustment plate", Items 1-5 on page 6.
2. Replace solenoid  
**Note solenoid no. and voltage!**
3. Remount hydraulic brake unit or adjustment plate as described in Section "Replacing hydraulic brake unit or adjustment plate", Items 7-11 on page 6.

**Remplacement de l'aimant MV .../5**

1. Déposer le frein hydraulique ou le disque de réglage, comme indiqué en page 6 "Remplacement du frein hydraulique ou du disque de réglage".
2. Remplacer l'aimant.  
**Tenir impérativement compte de la réf. de l'aimant et de la tension!**
3. Remonter le frein hydraulique ou le disque de réglage, comme indiqué en page 6 "Remplacement du frein hydraulique ou du disque de réglage".

**Sostituzione bobina MV .../5**

1. Togliere l'idraulico ed il piattello di regolazione come descritto a pag. 6 "sostituzione idraulico o piattello" punti da 1 a 5.
2. Sostituire la bobina.  
**Prestare assolutamente attenzione al numero della bobina e alla tensione!**
3. Rimontare l'idraulico ed il piattello di regolazione come descritto a pag. 6 "sostituzione idraulico o piattello" punti da 7 a 11.

**Magnetwechsel MV .../4**

1. Schutzkappe A entfernen.
2. Magnet auswechseln.  
**Magnet-Nr. und Spannung unbedingt beachten!**
3. Schutzkappe A aufschrauben.

**Changing solenoid MV .../4**

1. Remove dust cap A.
2. Replace solenoid  
**Note solenoid no. and voltage!**
3. Screw on dust cap A.

**Remplacement de l'aimant MV .../4**

1. Enlever le capot de protection A.
2. Remplacer l'aimant.  
**Tenir impérativement compte de la réf. de l'aimant et de la tension!**
3. Visser le capot de protection A.

**Sostituzione bobina MV .../4**

1. Togliere il cappuccio di protezione A.
2. Sostituire la bobina.  
**Prestare assolutamente attenzione al numero della bobina e alla tensione!**
3. Riavvitare il cappuccio di protezione A.

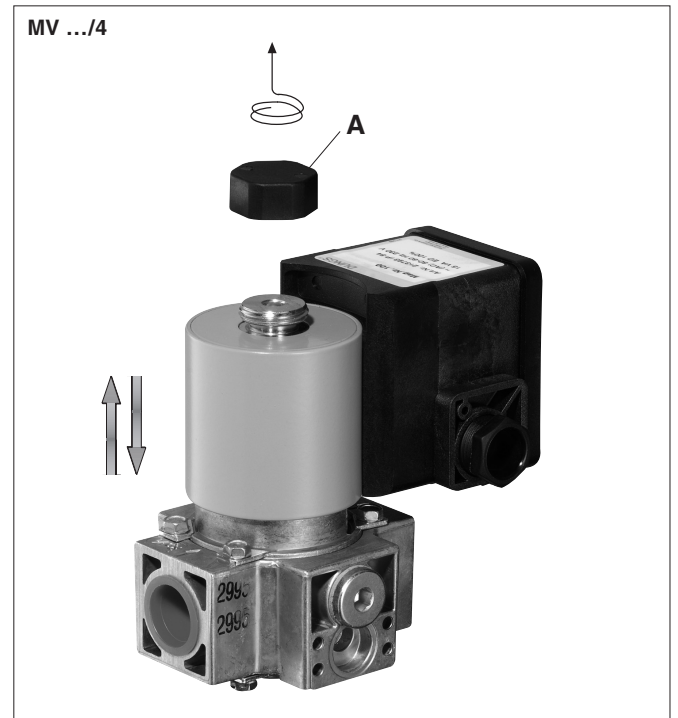
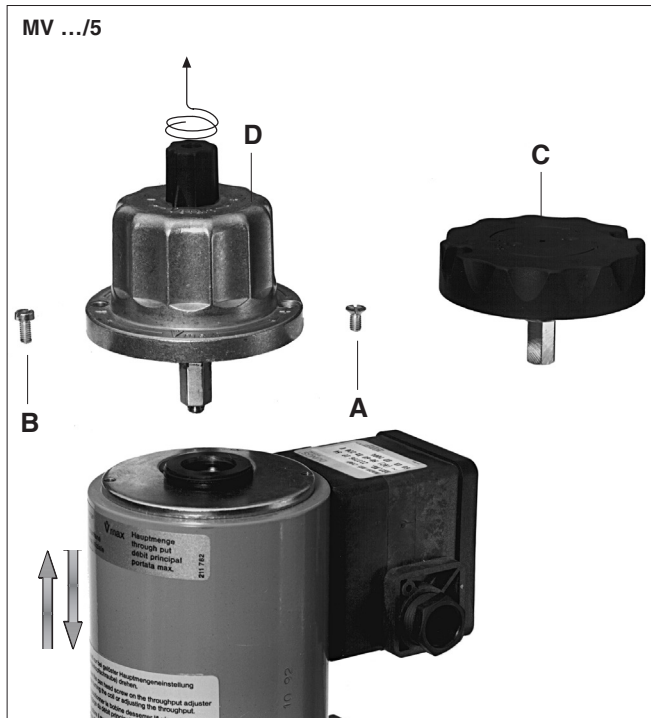

Durchfluß-Diagramm / Flow Diagram / Courbe des débits / Diagramma di portata

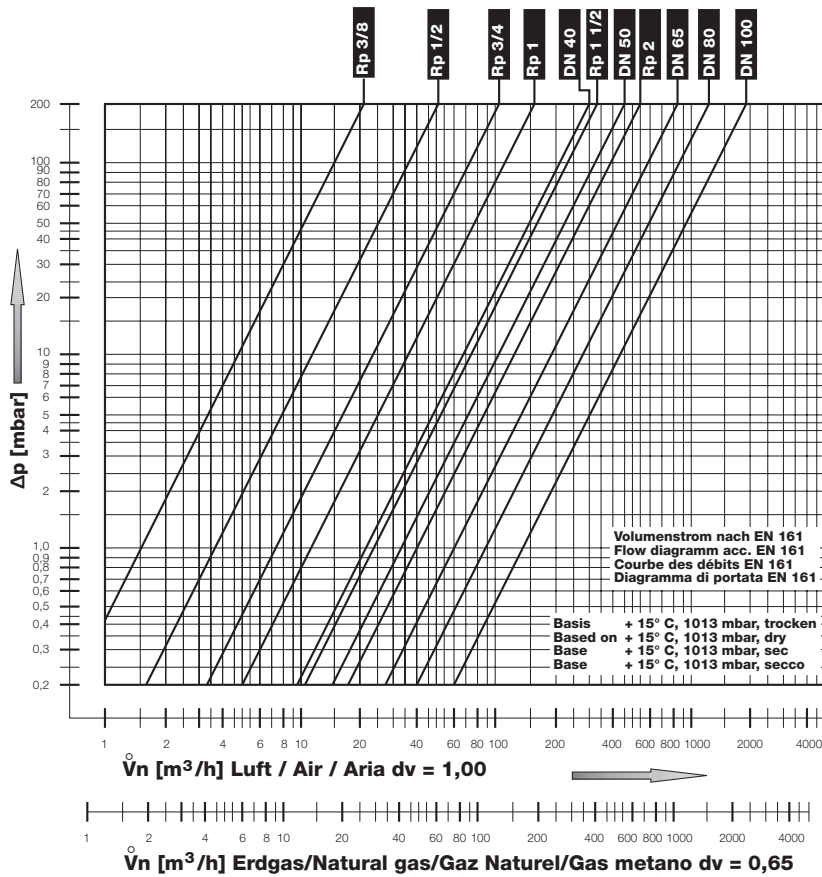

Strömungsgeschwindigkeit / Flow rate / Vitesse d'écoulement / Velocità Flusso

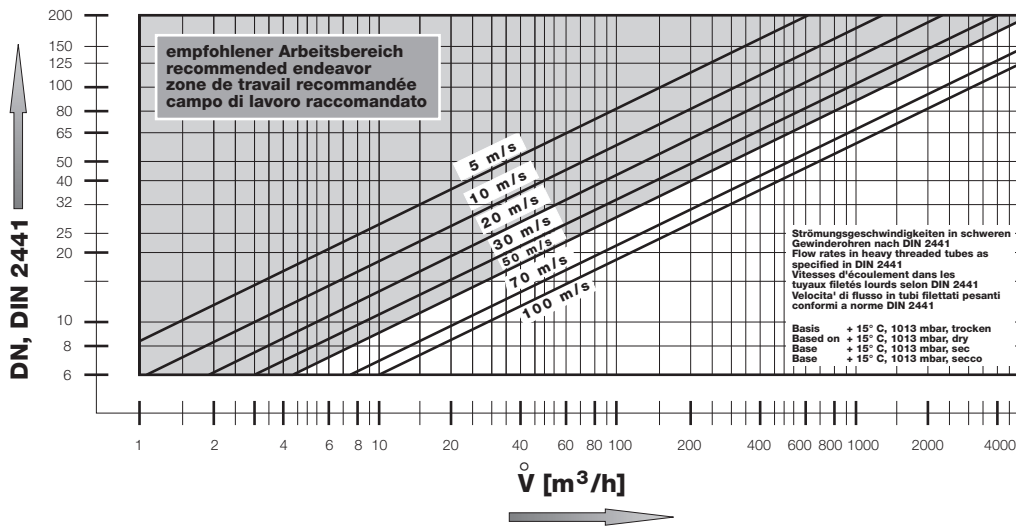

$$\dot{V}_{\text{verwendetes Gas/gas used/gaz utilisé/gas utilizzato}} = \dot{V}_{\text{Luft/air/aria}} \times f$$

f =

Dichte Luft  
Spec. weight air  
poids spécifique de l'air  
peso specifico aria

Dichte des verwendeten Gases  
Spec. weight of gas used  
poids spécifique du gaz utilisé  
peso specifico del gas utilizzato

Gasart  
Type of gas  
Type de gaz  
Tipo di gas

Dichte  
Spec. Wgt.  
poids spécifique  
Peso specifico  
[kg/m³]

$d_v$

f

Erdgas/Nat. Gas/  
Gaz naturel/Gas metano

0.81

0.65

1.24

Stadtgas/City gas/  
Gaz de ville/Gas città

0.58

0.47

1.46

Flüssiggas/LPG/  
Gaz liquide/Gas liquido

2.08

1.67

0.77

Luft/Air/  
Air/Aria

1.24

1.00

1.00



Ersatzteile / Zubehör Spare parts / Accessories Pièces de rechange / access. Parti di ricambio / Accessori	Bestell-Nummer Ordering No. No. de commande Codice articolo
<b>Verschlussschraube mit Dichtring</b> Locking screw and sealing ring <b>Bouchon fileté avec bague d'étanchéité</b> <b>Tappo a vite con guarnizione</b> G 1/8 G 1/4 G 3/4	5 Stück/Set 5 Pieces/Set 5 Pièces/Set 5 Pezzi/Set 230 395 230 396 230 402
<b>Steckverbindung DIN EN 175301-803 Set IP 54</b> Connector DIN EN 175301-803 <b>Set IP 54</b> Connexion DIN EN 175301-803 <b>Jeu IP 54</b> Collegamento a spina DIN EN 175301-803 <b>Set IP 54</b>	215 733
<b>Einstellteller für Hauptmenge Adjustment plate for main flow Disque de réglage pour débit principal</b> <b>Piattello regolazione per portata principale</b> Rp 3/8 – Rp 1/2 Rp 3/4 – Rp 2, DN 20 – DN 50 Rp 2 1/2, DN 65 – DN 100	231 789 231 790 231 791
<b>Hydraulikbremse Hydraulic brake Frein hydraulique freno idraulico</b> Rp 3/8 – Rp 1/2 Rp 3/4 – Rp 2, DN 20 – DN 50 Rp 2 1/2, DN 65 – DN 100	223 159 223 158 223 157
<b>Einsteckscheibe Insert washer Disque à emboîtement Dischetto da inserire</b> Rp 3/8 – Rp 1/2 Rp 3/4 – Rp 2, DN 20 – DN 50 Rp 2 1/2, DN 65 – DN 100	231 563 231 564 231 787
<b>Leitungsdose, schwarz Line socket, black Prise noire Spina, nera</b> GDMW, 3 pol. + E	215 699
<b>Dichtungen für Flanschen Measuring connections with sealing ring</b> Prise de pression avec joint <b>guarnizioni per flange</b> DN 40 DN 50 DN 65 DN 80 DN 100	2 Stück/Set 2 Pieces/Set 2 Pièces/Set 2 Pezzi/Set 231 600 231 601 231 603 231 604 231 605
<b>Stiftschraubensatz Set of setscrews Goujons Serie di viti per acciaio</b> M16 x 55 (DN 20 – DN 50) M16 x 65 (DN 65 - DN 100)	4 Stück/Set 4 Pieces/Set 4 Pièces/Set 4 Pezzi/Set 230 422 230 424
<b>Meßstutzen mit Dichtring Test nipple with sealing ring Prise de pression avec joint Misuratore con guarnizione</b> G 1/8 G 1/4	5 Stück/Set 5 Pieces/Set 5 Pièces/Set 5 Pezzi/Set 230 397 230 398

Ersatzteile / Zubehör Spare parts / Accessories Pièces de rechange / access. Parti di ricambio / Accessori	Bestell-Nummer Ordering No. No. de commande Codice articolo
<b>Schutzkappe Protective cap Capuchon protecteur Calotta di protezione</b> MV 2.../4 Rp 1/2 Rp 3/4 – Rp 2 MVD 2.../5 (p <sub>max</sub> 200 mbar) Rp 3/8 – Rp 1/2 Rp 3/4 – Rp 2, DN 20 – DN 50 Rp 2 1/2, DN 65 – DN 100 MVD 5.../5 (p <sub>max</sub> 500 mbar) Rp 3/8 – Rp 1/2 Rp 3/4 – Rp 2, DN 20 – DN 50 DN 50 – DN 65 Rp 2 1/2, DN 80 MVDLE 2.../5 + MVDLE 5.../5 Rp 3/8 – Rp 2, DN 20 – DN 50 Rp 2 1/2, DN 65 – DN 100	5 Stück/Set 5 Pieces/Set 5 Pièces/Set 5 Pezzi/Set 231 795 231 796 231 795 231 796 231 797 231 795 231 796 231 797 231 798 231 799 231 796
<b>Ersatzmagnet Replacement solenoid Bobine de rechange Bobina di ricambio</b>	auf Anfrage on request sur demande su richiesta



Arbeiten am Magnetventil dürfen nur von Fachpersonal durchgeführt werden.

Work on the solenoid valve may only be performed by specialist staff.

Seul du personnel spécialisé peut effectuer des travaux sur l'électrovanne.

Qualsiasi operazione effettuata sulle valvole deve essere fatta da parte di personale competente.

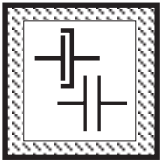

Flanschflächen schützen. Schrauben kreuzweise anziehen. Auf mechanisch spannungsfreien Einbau achten.

Protect flange surfaces. Tighten screws crosswise. Mount tension free.

Protéger les surfaces de brides. Serrer les vis en croisant. Eviter les tensions mécaniques lors du montage.

Proteggere le superfici della flangia. Stringere le viti in modo incrociato. Fare attenzione a che il montaggio meccanico sia senza tensioni.

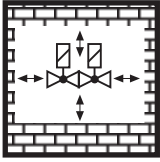

Direkter Kontakt zwischen Magnetventil und dem aushärtendem Mauerwerk, Betonwänden, Fußböden ist nicht zulässig.

Do not allow any direct contact between the solenoid valve and hardened masonry, concrete walls or floors.

Eviter tout contact direct entre l'électrovanne et la maçonnerie, les cloisons en béton et planchers en cours de séchage.

Non é consentito il contatto diretto fra la valvola e murature invecchiate, pareti in calcestruzzo, pavimenti.

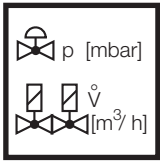

Nennleistung bzw. Drucksollwerte grundsätzlich am Gasdruckregelgerät einstellen. Leistungsspezifische Drosselung über das Magnetventil MVD .../5.

Always adjust nominal output or pressure setpoints on the gas pressure regulator and performance-specific throttling using the MVD .../5.

Régler toujours le débit nominal ou les pressions de consigne sur le régulateur de pression. Limitation au niveau de MVD .../5, en fonction du débit.

Effettuare in linea di massima la regolazione di potenza nominale e valori nominali di pressione sul regolatore di pressione gas. La regolazione specifica di potenza va fatta attraverso la MVD .../5.



Grundsätzlich nach Teileausbau/umbau neue Dichtungen verwenden.

Always use new seals after dismantling and mounting parts.

Après un démontage ou une modification, utiliser toujours des joints neufs.

In linea di massima, dopo lo smontaggio e il rimontaggio di alcune parti, utilizzare nuove guarnizioni.

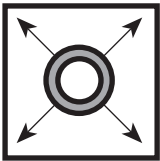

Rohrleitungsdichtheitsprüfung: Kugelhahn vor den Armaturen, MV .../4, MV .../5 schließen.

Pipeline leakage test: close ball valve upstream of fittings, MV .../4, MV .../5.

Contrôle de l'étanchéité de la conduite: fermer le robinet à boisseau sphérique avant les électrovannes, MV .../4, MV .../5.

Per la prova di tenuta delle tubature: chiudere il rubinetto a sfera davanti ai corpi valvola, MV .../4, MV .../5.



Nach Abschluß von Arbeiten am Magnetventil: Dichtheits- und Funktionskontrolle durchführen.

On completion of work on the solenoid valve, perform a leakage and function test.

Une fois les travaux sur l'électrovanne terminés, procéder toujours à un contrôle d'étanchéité et de fonctionnement.

Al termine dei lavori effettuati su una valvola elettromagnetica: predisporre un controllo sia della tenuta che del funzionamento.



Niemals Arbeiten durchführen, wenn Gasdruck oder Spannung anliegt. Offenes Feuer vermeiden. Öffentliche Vorschriften beachten.

Never perform work if gas pressure or power is applied. No naked flame. Observe public regulations.

Ne jamais effectuer des travaux lorsque la pression ou la tension sont présentes. Eviter toute flamme. Observer les réglementations.

In nessun caso si debbono effettuare lavori in presenza di pressione gas o di tensione elettrica. Evitare i fuochi aperti e osservare le prescrizioni pubbliche.



Bei Nichtbeachtung der Hinweise sind Personen- oder Sachfolgeschäden denkbar.

If these instructions are not heeded, the result may be personal injury or damage to property.

En cas de non-respect de ces instructions, des dommages corporels ou matériels sont possible.

La non osservanza di quanto suddetto può implicare danni a persona o cose.



Alle Einstellungen und Einstellwerte nur in Übereinstimmung mit der Betriebsanleitung des Kessel-/Brennerherstellers ausführen.

Any adjustment and application-specific adjustment values must be made in accordance with the appliance-/boiler manufacturers instructions.

Effectuer tous les réglages et réaliser les valeurs de réglage uniquement selon le mode d'emploi du fabricant de chaudières et de brûleurs.

Realizzare tutte le impostazioni e i valori impostati solo in conformità alle istruzioni per l'uso del costruttore della caldaia/ del bruciatore.





Die Druckgeräterichtlinie (PED) und die Richtlinie über die Gesamtenergieeffizienz von Gebäuden (EPBD) fordern eine regelmässige Überprüfung von **Heizungsanlagen** zur langfristigen Sicherstellung von hohen Nutzungsgraden und somit geringster Umweltbelastung. **Es besteht die Notwendigkeit sicherheitsrelevante Komponenten nach Erreichen ihrer Nutzungsdauer auszutauschen. Diese Empfehlung gilt nur für Heizungsanlagen und nicht für Therprozessenanwendungen. DUNGS empfiehlt den Austausch gemäss folgender Tabelle:**

The Pressure Equipment Directive (PED) and the Energy Performance of Buildings Directive (EPBD) require a periodic inspection of **heating appliances** in order to ensure a high degree of efficiency over a long term and, consequently, the least environmental pollution. **It is necessary to replace safety-relevant components after they have reached the end of their useful life. This recommendation applies only to heating appliances and not to industrial heating processes. DUNGS recommends replacing such components according to the following table:**

La directive concernant les chauffe-bains à pression (PED) et la directive sur la performance énergétique des bâtiments (EPBD) exigent une vérification régulière des installations de chauffage, afin de garantir à long terme des taux d'utilisation élevés et par conséquent une charge environnementale minimum. **Il est nécessaire de remplacer les composants relatifs à la sécurité lorsqu'ils ont atteint la fin de leur vie utile. Cette recommandation ne s'applique qu'aux installations de chauffage et non aux applications de processus thermique. DUNGS recommande le remplacement, conformément au tableau qui suit :**

La direttiva per apparecchi a pressione (PED) e la direttiva per l'efficienza dell'energia totale per edifici (EPBD), esigono il controllo regolare degli impianti di riscaldamento per la garanzia a lungo termine di un alto grado di rendimento e con ciò di basso inquinamento ambientale. **Ciò rende necessaria la sostituzione di componenti rilevanti dal punto di vista della sicurezza alla scadenza della loro durata di utilizzazione. Questo suggerimento vale solo per impianti di riscaldamento e non per impieghi per processi termici. DUNGS consiglia detta sostituzione in conformità alla sottostante tabella:**

Sicherheitsrelevante Komponente Safety relevant component Composant relatif à la sécurité Componenti rilevanti dal punto di vista della sicurezza	NUTZUNGSDAUER DUNGS empfiehlt den Austausch nach: USEFUL LIFE DUNGS recommends replacement after: VIE UTILE DUNGS recommande le remplacement au bout de : DURATA DI UTILIZZAZIONE DUNGS consiglia la sostituzione dopo:	Schaltspiele Operating cycles Cycles de manoeuvres Cicli di comando
Ventilprüfsysteme / Valve proving systems Systèmes de contrôle de vannes / Sistemi di controllo valvole	10 Jahre/years/ans/anni	250.000
Druckwächter / Pressure switch / Manostat / Pressostati	10 Jahre/years/ans/anni	N/A
Feuerungsmanager mit Flammenwächter Automatic burner control with flame safeguard Dispositif de gestion de chauffage avec contrôleur de flammes Gestione bruciatore con controllo fiamma	10 Jahre/years/ans/anni	250.000
UV-Flammenfühler Flame detector (UV probes) Capteur de flammes UV Sensore fiamma UV	10.000 h Betriebsstunden / Operating hours Heures de service / Ore di esercizio	
Gasdruckregelgeräte / Gas pressure regulators Dispositifs de réglage de pression du gaz / Regolatori della pressione del gas	15 Jahre/years/ans/anni	N/A
Gasventil mit Ventilprüfsystem / Gas valve with valve testing system Vanne de gaz avec système de contrôle de vanne / Valvola del gas con sistema di controllo valvola	nach erkanntem Fehler / after error detection après détection du défaut / dopo il rilevamento di errori	
Gasventil ohne Ventilprüfsystem* / Gas valve without valve testing system* Vanne de gaz sans système de contrôle de vanne* / Valvola del gas senza sistema di controllo valvola*	10 Jahre/years/ans/anni	250.000
Min. Gasdruckwächter / Low gas pressure switch Manostat de gaz min. / Pressostato gas min.	10 Jahre/years/ans/anni	N/A
Sicherheitsabblaseventil / Pressure relief valve Soupape d'évacuation de sécurité / Valvola di scarico di sicurezza	10 Jahre/years/ans/anni	N/A
Gas-Luft-Verbundsysteme / Gas-air ratio control system Systèmes combinés gaz/air / Sistemi di miscelazione gas-aria	10 Jahre/years/ans/anni	N/A
* Gasfamilien I, II, III / Gas families I, II, III Familles de gaz I, II, III / per i gas delle famiglie I, II, III	N/A kann nicht verwendet werden / not applicable ne peut pas être utilisé / non può essere usato	

**Hausadresse**  
Head Offices and Factory  
Usine et Services Administratifs  
Amministrazione e Stabilimento

**Karl Dungs GmbH & Co. KG**  
Siemensstr. 6-10  
D-73660 Urbach, Germany  
Telefon +49 (0)7181-804-0  
Telefax +49 (0)7181-804-166

**Briefadresse**  
Postal address  
Adresse postale  
Indirizzare la corrispondenza a

**Karl Dungs GmbH & Co. KG**  
Postfach 12 29  
D-73602 Schorndorf  
e-mail [info@dungs.com](mailto:info@dungs.com)  
Internet [www.dungs.com](http://www.dungs.com)